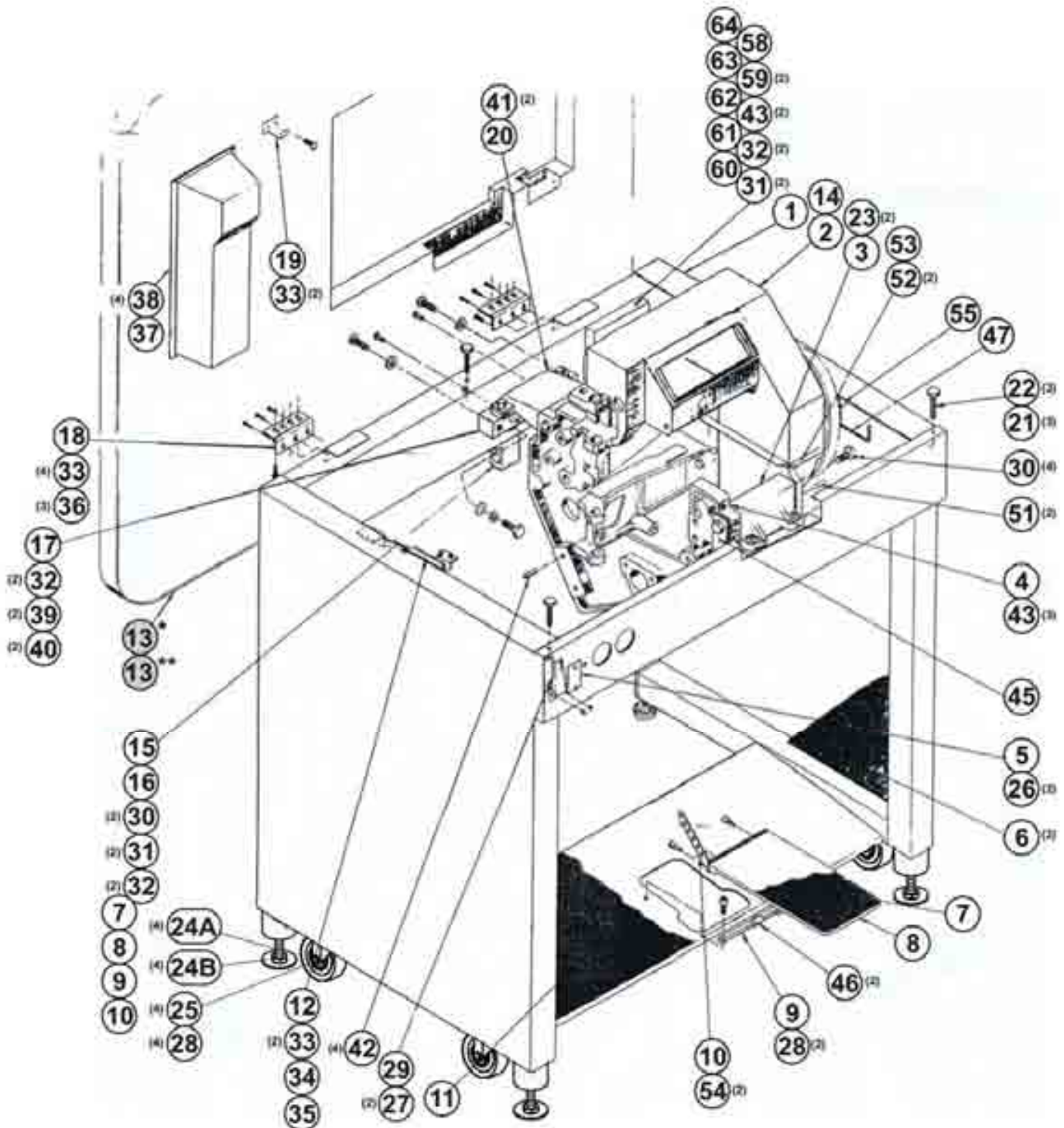

TABLE OF CONTENTS

Main Frame Assembly	3-2
Cam and Gears	3-6
Upper Needle Bar Mechanism	3-8
Presser Foot Mechanism	3-12
Lower Needle Bar Mechanism	3-16
Lower Looper and Thread Drum Mechanism	3-18
Main Cam Shaft Assembly	3-22
Thread Gripper & Elevator Mechanism	3-24
Pick Stitch & Tension Finger	3-26
Tension Finger Assembly	3-30
Material Feed	3-32
Angle Stitch Mechanism	3-36
Upper Looper	3-38
Work Plate Assembly	3-42
Presser Foot & Swivel Toe Assembly	3-44
Presser Foot	3-46
ELECTRICAL - I	3-48
ELECTRICAL - II	3-50
ELECTRICAL - III	3-52
Accessories	3-54
Thread Trim	3-56
Foot Pedal	3-58
Condensed Stitch Kit	3-60
ELECTRICAL diagram	3-62
Material Gauge	3-64

MAIN FRAME ASSEMBLY



Revised 10/2011

e-mail: service@amfreece.cz; parts@amfreece.cz; website: www.amfreece.com

Phone: +420 582 309 286; Fax: +420 582 360 606

MAIN FRAME ASSEMBLY

DET	PART NUMBER	DESCRIPTION	QTY
01	04.9070.0.000	Main Frame	1
02	41321019	Needle Bar Hd. Assembly	1
03	35371003	Front Spacer	1
04	35315013	Tie Frame	1
05	37711017	Name Plate	1
06	70.3271.1.020	Sound Isolation ● ● ●	2
07	70.3325.1.108	Holder	1
08	08.6200.4.010	Screw M4-10	4
09	08.6700.4.000	Nut M4	2
10	08.6850.4.000	Washer M4	6
11	32216086	Foot Plate Tread ● ● ●	1
12	41441060	Table Support	1
13*	70.3535.1.181	Table Top ● ● ●	1*
13**	35351180	Table Top ● ● ●	1**
15			
16	70.3325.1.109	Motor Holder	1
17			
18	41214006	Hinge	2
19	70.3535.1.182	Hook	1
20	35472011	Spacer, Rear, Tie Frame	1
21	01200024	Screw #3/8 - 16x1	3
22	06020015	Nut, Hex.Jam # 3/8 -16	3
23	01000047	Scr., Hex. Soc. Hd. Cap # 5/16 - 18 x1	2
24A	12.0008.6.523	Screw M12	4
24B	12.0008.6.521	Leveling Pad	4
25	12.0008.6.520	Castor Wheels	4
26		Rivet	2
27		Scr., Rd.Hd. Mach. # 6 - 32 x 1/4	2
28	08.6000.0.025	Screw	4
29	22972010	Latch 'Camloc' # 51 L1-1- 1 AB -	1
30	04200003	Scr. Hex.Hd. # 3/8 - 16 x 1	6
31	07100009	Washer, Spring Lock # 3/8	4
32	07012003	Washer, Flat # 3/8	6
33	02060018	Scr. Pan Hd. (Type A) # 10 x 5/8	12
34	22911038	Scr., Asa Lock #1 A	1
35		Nut, Lock "ESNA" #21 NTE- 058-	1
36	04140040	Scr., Truss Hd. # 10 - 32 x 5/16	6
37	27571120	Drawer.Stl."Superior" # 333 Grey ● ● ●	1
38		Scr., Fl.Hd. Wood # 8 x 3/4-	4
39	01200024	Scr. Hex .Soc .But Hd.# 3/8 - 16 x 1	2
40	08200024	Spring Pin 1/4" x 1	2
41	04200027	Scr., Hex.Hd. # 5/16 - 18 x 1	2
42	08000019	Pin, Dowel # 1/4 x 1 1/4	4
43	04200004	Scr.Hex. Hd. # 3/8 - 16 x 1 1/2	5
44			
45	34416044	Bracket, Switch Mount	1
46			
47			
48			

* — Modification Standard

** — Modification Pick Stitch



Revised 07/2012

 e-mail: service@amfreece.cz; parts@amfreece.cz; website: www.amfreece.com

Phone: +420 582 309 246; Fax: +420 582 360 606

MAIN FRAME ASSEMBLY

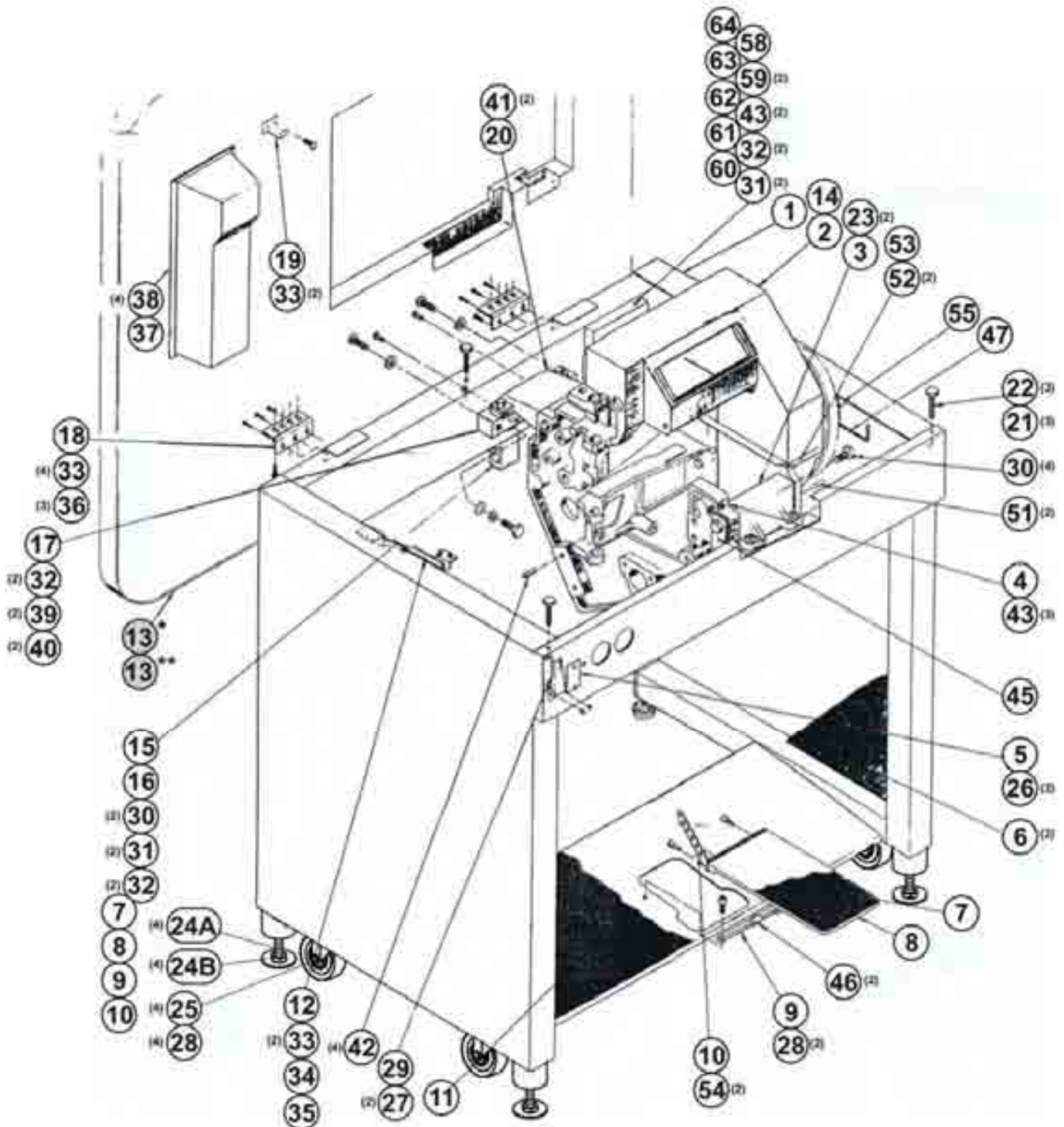



Revised 10/2011

e-mail: service@amfreece.cz; parts@amfreece.cz; website: www.amfreece.com

Phone: +420 582 309 286; Fax: +420 582 360 606

MAIN FRAME ASSEMBLY

DET	PART NUMBER	DESCRIPTION	QTY
51		Pin , Dowel # 5/16 x 3/4	4
52	04100052	Scr. Bind. Hd.# 8 - 32 x 1/4	2
53	34268125	Angle, Filler	1
54			
55			
56			
57			
58	70.3162.5.003	Pulley assembly	1
59	06000014	Nut. Hex.# 3/8 -16	2
60	23522009	Counter Shaft Bearing	1
61	34125140	Box Cover	1
62			
63	24323130	"V" Belt 	1
64	24423030	Pulley, "V" Belt 	1
65	35523026	Counter Shaft Bracket	1
66	70.3100.0.042	Facia Plate	1
67	70.3265.2.016	Cover	1
68			
69	12.0008.6.517	Caster	4
70	70.3165.2.002	Sensor Holder	1
71			
72	24473075	Pulley	1
73	24383030	Belt 285L075	1
74	12.8000.1.010	Label (DECO)	1
75	12.1016.0.001	Nail 2,6x6	2
76	70.3577.7.047	Cover Rear	1
77	70.3577.7.044	Cover Pulley	1
78			
79	08.6000.4.008	Screw	4
90	31852010	Alex Light Holder	1
100			
101	31000030	Hook Facia Plate	1
102	31000031	Lock Facia Plate	1

Released 06/2010

e-mail: service@amfreece.cz; parts@amfreece.cz; website: www.amfreece.com

Phone: +420 582 309 246; Fax: +420 582 360 606

CAM AND GEARS

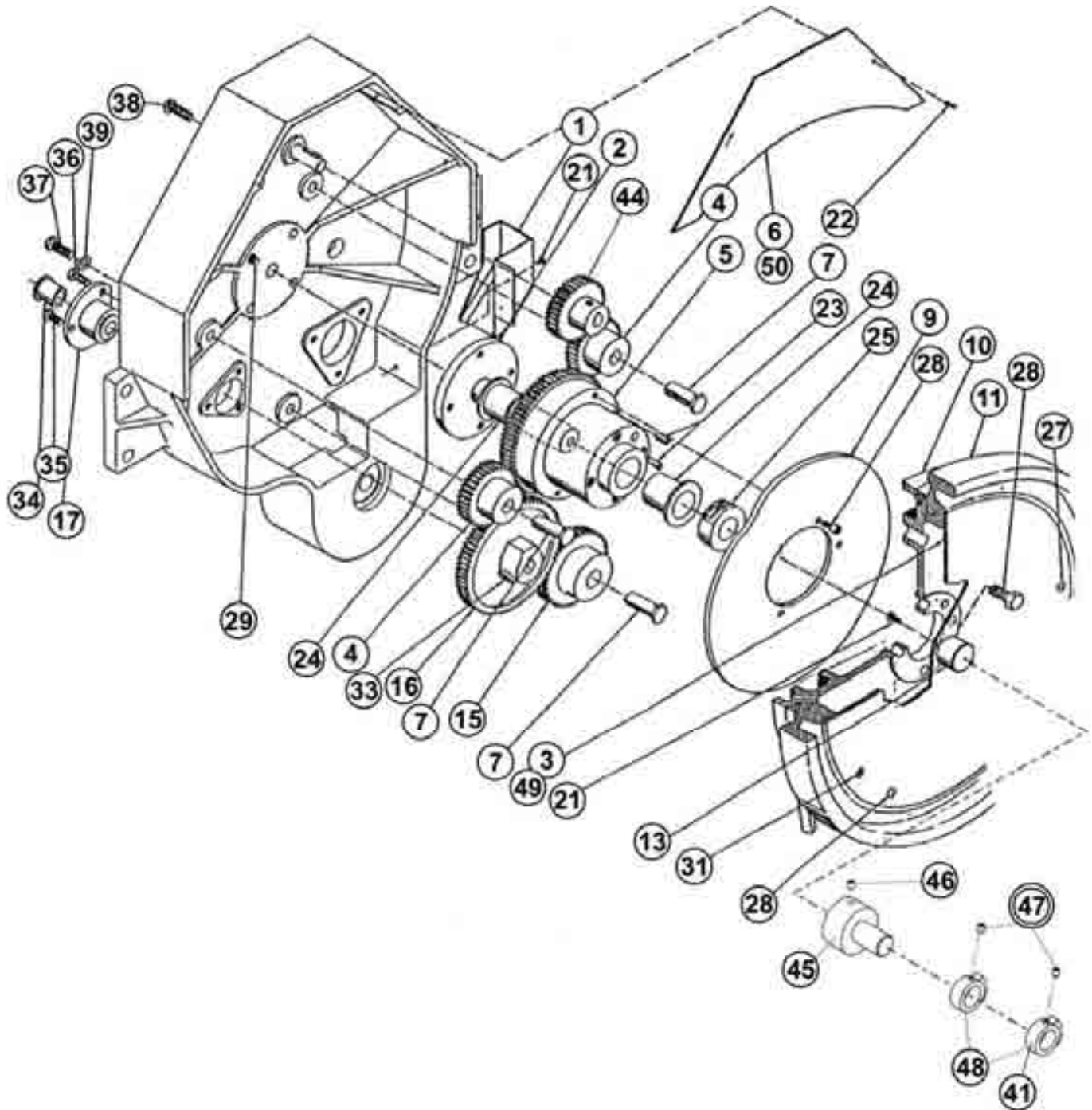

Revised 06/2013

e-mail: service@amfreece.cz; parts@amfreece.cz; website: www.amfreece.com

Phone: +420 582 309 286; Fax: +420 582 360 606

CAM AND GEARS

DET	PART NUMBER	DESCRIPTION	QTY
01	35812049	Cover, Rear Drum	1
02	31766009	Drive Gear Stud	1
03	31523037	Cover, Handwheel	1
04	36224010	Small Intermediate Gear ● ● ●	2
05	36228020	Drive Gear	1
06	32652015	Guard, Belt	1
07	31838030	Gear Stud	3
08			
09	70.3651.3.048	Left Upper Looper Cam	1
10	36516040	Needle Bar Cam	1
11	36713007	Needle Bar Hand Wheel ● ● ●	1
12			
13	31652001	Sensor Drive Shaft	1
14			
15	36226017	Large Intermediate Gear ● ● ●	1
16	36228009	Cam Shaft Drive Gear	1
17	36515032	Cam Shaft Bearing	1
18			
19			
20			
21	04100054	Scr. Binding # Hd. 8- 32 x 3/8	2
22	01200005	Scr. , Hex. Soc. But. Hd.# 8 - 32 x 3/8	2
23	08200031	Pin, Roll # 3/16 x 3/8	1
24	23161140	Bearing,"Oilite" # FF - 1213-4 ● ●	2
25	24116150	Collar, Set SC 100 1" I.D	1
26	04200057	Scr. Hex. Soc. Cap # 10 - 32 x 1/2	1
27	04200003	Scr., Hex. Hd.# 3/ 8 - 16 x 1	4
28	01200001	Scr. Hex. Soc. But. Hd. # 140- 32 x 1/2	2
29	01000099	Scr. Hex. Soc. Cap # 5/16 - 18 x 5/8	1
30			
31	01002040	Scr. Hex. Soc. Cap # 5/16 - 18 x 3/4	1
32			
33	03200023	Scr. Hex. Soc. Hd. Cup PT.# 1/4 - 20 x 1/2	1
34	23161063	Bushing, "Oilite" # FF - 707 - 2 ● ●	1
35	04200013	Scr., Hex. Hd. # 1/4 - 20 x 5/8	1
36	04200012	Scr., Hex. Hd. # 1/4 - 20 x 1/2	1
37	04200267	Scr., Hex. Hd. # 3/8 - 24 x 1	1
38	01200083	Scr., But. Hex. Soc.# 3/8 - 24 x 1	1
39	07100009	Washer, Lock # 3/8	1
40	70.3165.2.002	Sensor Holder	1
41	19.0044.1.624	Ring Sensor	1
42	17.0011.2.013	Screw M6x0, 75 x 6	2
43	08.6400.4.008	Screw M4 - 8	1
44	36224009	Gear	1
45	70.3165.2.003	Adaptor	1
46	08.6400.4.006	Screw M4x6	1
47	17.0011.2.013	Screw	(2)
48	19.0044.1.625	Ring Sensor	1

Released 03/2011

 e-mail: service@amfreece.cz; parts@amfreece.cz; website: www.amfreece.com

Phone: +420 582 309 246; Fax: +420 582 360 606

UPPER NEEDLE BAR MECHANISM

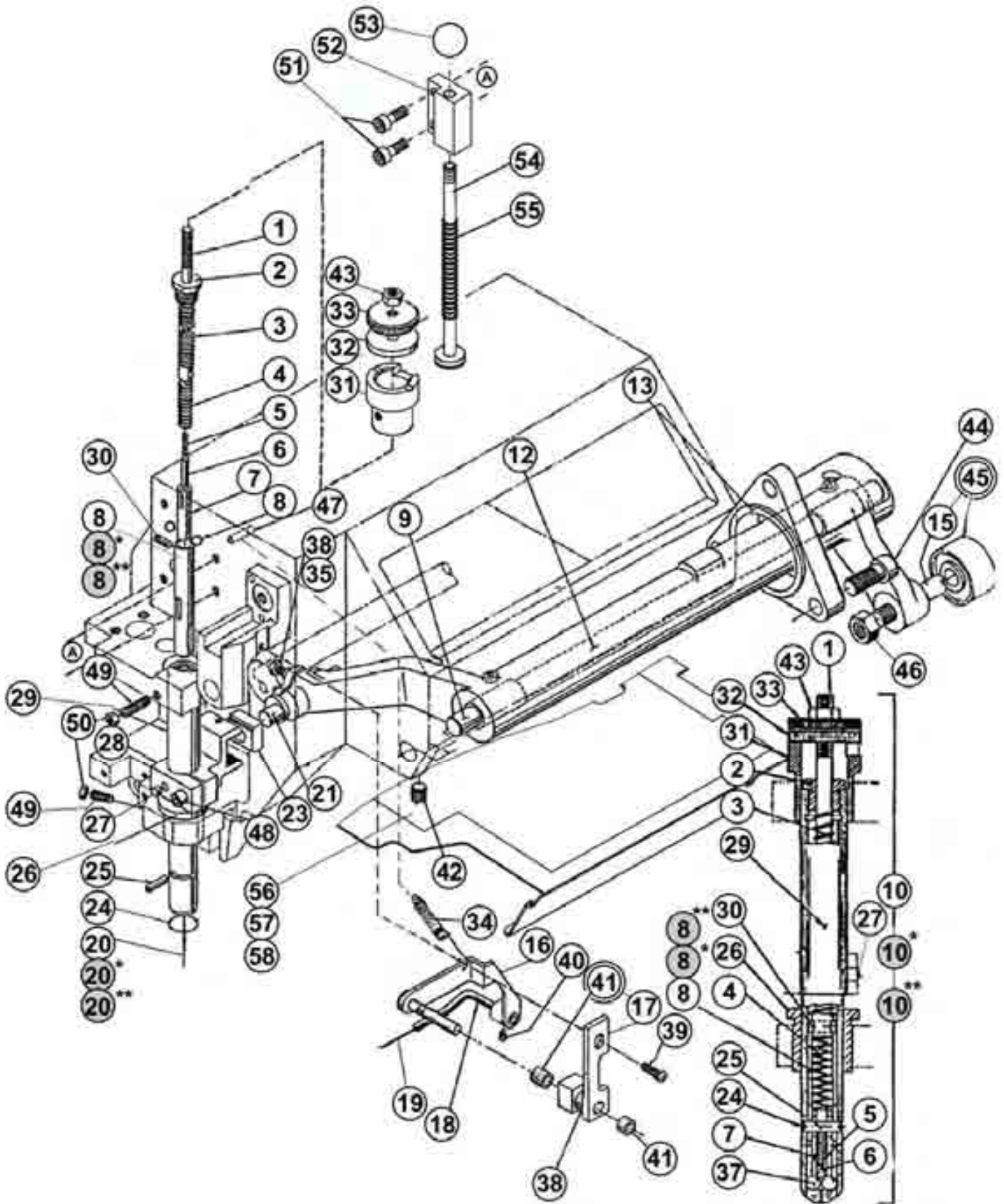

Revised 07/2013

e-mail: service@amfreece.cz; parts@amfreece.cz; website: www.amfreece.com

Phone: +420 582 309 286; Fax: +420 582 360 606

UPPER NEEDLE BAR MECHANISM

DET	PART NUMBER	DESCRIPTION	QTY
01	31674025	Sleeve Extension	1
02	31695011	Needle bar Spring Cap	1
03	36532021	Needle Bar Spring	1
04	36532022	Needle Lock Spring	1
05	36531010	Needle Stop Spring	1
06	36771021	Needle Stop	1
07	31566008	Needle Clamp Sleeve	1
08	35511021	Needle Support Sleeve	1
08*	35511061	Needle Support Sleeve	1*
08**	35511048	Needle Support Sleeve	1**
09	31723007	Rocker Arm Pivot	1
10	42531081	Needle Bar Assembly	1
10*	70.4253.1.078	Needle Bar Assembly	1*
10**	70.4253.1.079	Needle Bar Assembly	1**
12	36691014	Needle Bar Rocker Arm	1
13	35521048	Rocker Arm Bearing	1
15	31773015	Rocker Arm Bearing Stud	1
16	36631031	Assembly- Threader Lever	1
17	33215069	Threader Bearing	1
18	31996006	Threader Arm	1
19	37213001	Threader Needle	1
20	00103238	Round Needle - size 38	1
20*	00103228	Round Needle - size 28	1*
20**	00103249	Round Needle - size 49	1**
21	36518030	Bearing Block Stud	1
23	33182005	Needle Bar Bearing Block	1
24	35131002	Pin Retainer	1
25	31264001	Stop Pin	1
26	36523022	Needle Bar Small Bush	1
27	31151001	(Locating Pin) = part of Assembly 33441003	1
28	33441003	Needle Bar Clamp Upper	1
29	31697003	Needle Bar	1
30	31111009	Sleeve Ext. Conn. Pin	1
31	70.3652.3.023	Large Bushing	1
32	31412001	Spring Plunger Washer ●●●	1
33	31593007	Sleeve Adjust.Nut	1
34	36546023	Spring , Threader	1
35	04200011	Scr.,Mach. Hex. Hd #10 - 32 x 5/8	1
36	07106002	Washer, Lock. Hi - Collar # 10	1
37	22965006	Ball. Stl." New Depart"# 11(64 Dia	2
38	24116020	Collar	1
39	01200007	Scr. Hex. Soc. But. Hd.# 10 - 32 x 3/8	1
40	01000298	Scr. Hex. Soc. Hd. Cap.# 5 - 40 x 1/8	1
41	23132030	Bushing Oilite #AA 309 ●●	(2)
42	03100008	Scr. Set Hex. Soc. Cap Pt.# 1/4 - 20 x 1/4	1
43	06002001	Nut. Hex. S. Stl. # 10 - 32	1
44	01000039	Scr. Hex. Soc. Hd. Cap # 5/16 - 18 x 3/4	3

* — Extra Parts Needle size 28

** — Extra Parts Needle size 49

Revised 12/2011

e-mail: service@amfreece.cz; parts@amfreece.cz; website: www.amfreece.com

Phone: +420 582 309 246; Fax: +420 582 360 606

UPPER NEEDLE BAR MECHANISM

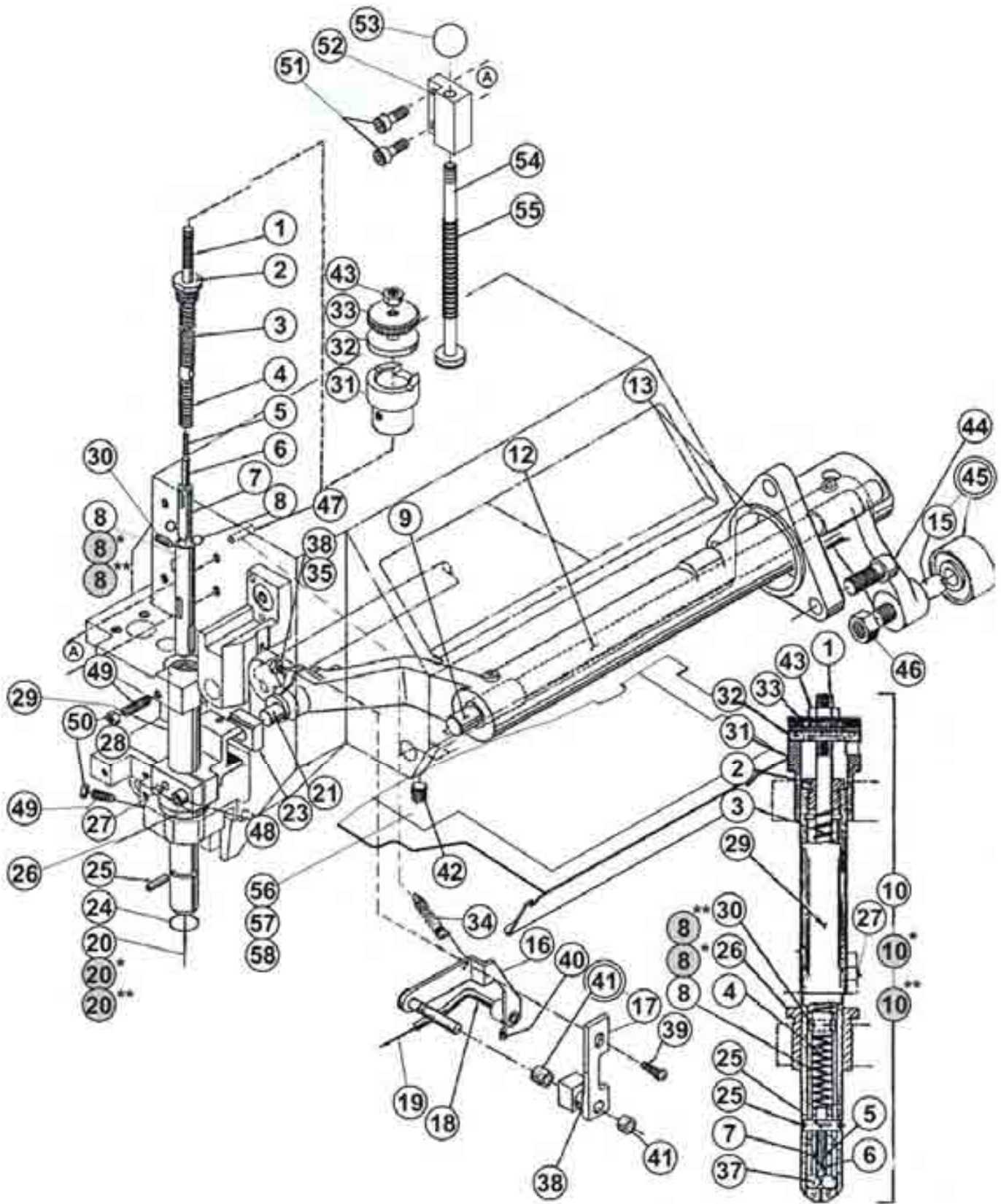

Revised 12/2011

e-mail: service@amfreece.cz; parts@amfreece.cz; website: www.amfreece.com

Phone: +420 582 309 286; Fax: +420 582 360 606

UPPER NEEDLE BAR MECHANISM

DET	PART NUMBER	DESCRIPTION	QTY
45	23231030	Bearing , Ball	(1)
46	06104001	Locknut, " ESNA" 29 NTE- 54-	1
47	31721039	Pin Groove "Drive Loc"#1/4 x 1 (Type G)	1
48	01000013	Scr. Hex.Soc.Hd.Cap# 8 - 32 x 1/2	1
49	03130001	Scr., Hex. Soc. Cone Pt. # 8 - 32 x 1/2	2
50	06020019	Nut. Jam Hex. # 8 - 32	2
51	08.6000.4.012	Screw	2
52	70.3652.3.026	Block ● ● ●	1
53	12.0008.6.979	Ball	1
54	70.3652.3.025	Bar	1
55	12.3010.0.014	Spring	1
56	70.3265.2.017	Cover	1
57	70.3271.1.025	Sound Isolation	1
58	08.6200.3.005	Screw M3x5	4

* — Extra Parts Needle size 28
 ** — Extra Parts Needle size 49

Revised 12/2011

e-mail: service@amfreece.cz; parts@amfreece.cz; website: www.amfreece.com

Phone: +420 582 309 246; Fax: +420 582 360 606

PRESSER FOOT MECHANISM

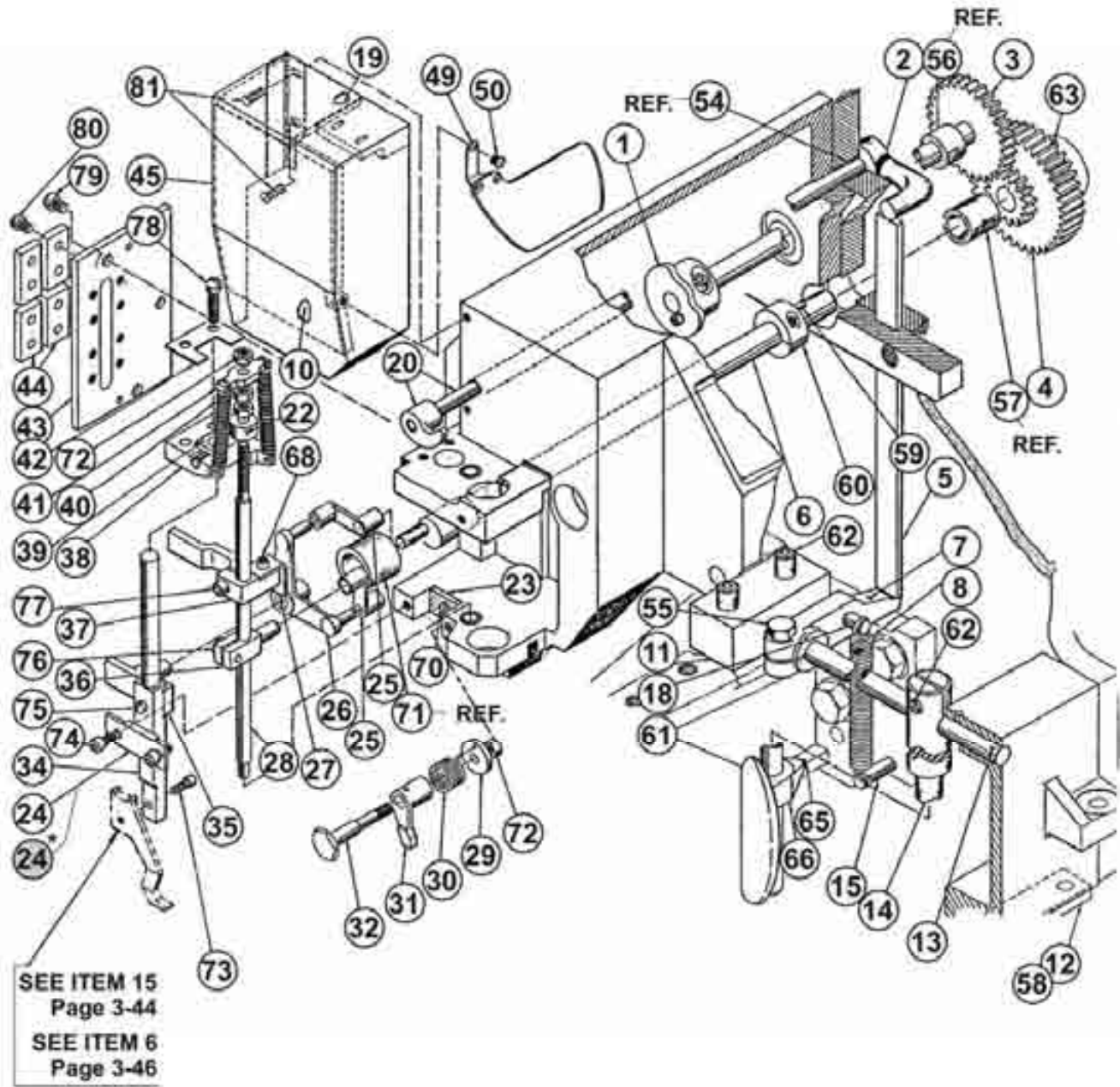

Revised 07/2013

e-mail: service@amfreece.cz; parts@amfreece.cz; website: www.amfreece.com

Phone: +420 582 309 286; Fax: +420 582 360 606

PRESSER FOOT MECHANISM

DET	PART NUMBER	DESCRIPTION	QTY
01	70.4223.3.029	Ass'y, Rt. Upper Looper Cam	1
02	36651001	Lifter Lever. P. F.	1
03	36227019	Ass'y, Shaft Rt. Looper Cam	1
04	36271013	Ass'y, Presser Ft. Drive Gr.	1
05	32111012	Lifter Rod	1
06	36518077	Operation Shaft	1
07	36651002	Lifter Lever	1
08	36543018	Lever Spring	1
09			
10	32731026	Sound Suppressor	1
11	35521055	Presser Foot Bearing	1
12			
13	31133018	Presser Ft. Oper. Shaft	1
14	70.3172.1.024	Knee Oper. Shaft	1
15	31721040	Spring Post	1
16			
17			
18	31721038	Spring Post	1
19	32115013	Sound Suppressor	1
20	36619044	Shaft/ Press. Ft. Lifter	1
21			
22	31571002	Stationary Press. Foot Cap	1
23	32217002	Follower Side Guide Plate	1
24	33242002	Retainer Strap	1
24*	70.3324.2.003	Retainer Strap (Back-Tack)	1
25	36621001	Connector Link	2
26	36672047	Lifting Bell Crank	1
27	34221010	Conn. Link Retainer	1
28			
29	31521001	Adjusting Collar	1
30	36543020	Torsion Spring	1
31	36613036	Spring Lever	1
32	31718027	Lever Stud	1
33			
34	31642007	Follow. Press. Ft. Shaft	1
35	35571021	Bell Crank Stud	1
36	31873013	Presser Foot Stud	1
37	33422001	Connector Link Block	1
38	33256011	Swivel Seat	1
39	31876011	Foot Swivel	1
40	36541005	Sprg. Tens. Follow. Ft	2
41	32729001	Clip Spring	1
42	32732001	Swivel Seat Cover	1
43	34732023	Rear Cover	1
44	32221007	Bell Crank Stud Guide	4
45	35771051	Ass'y Front Cover	1
46			
47			
48			
49	70.2691.1.188	Eye Guard	1
50	04100070	Scr. Bind. Hd. # 1/4 - 20 x 3/8	1

Revised 12/2011

 e-mail: service@amfreece.cz; parts@amfreece.cz; website: www.amfreece.com

Phone: +420 582 309 246; Fax: +420 582 360 606

PRESSER FOOT MECHANISM

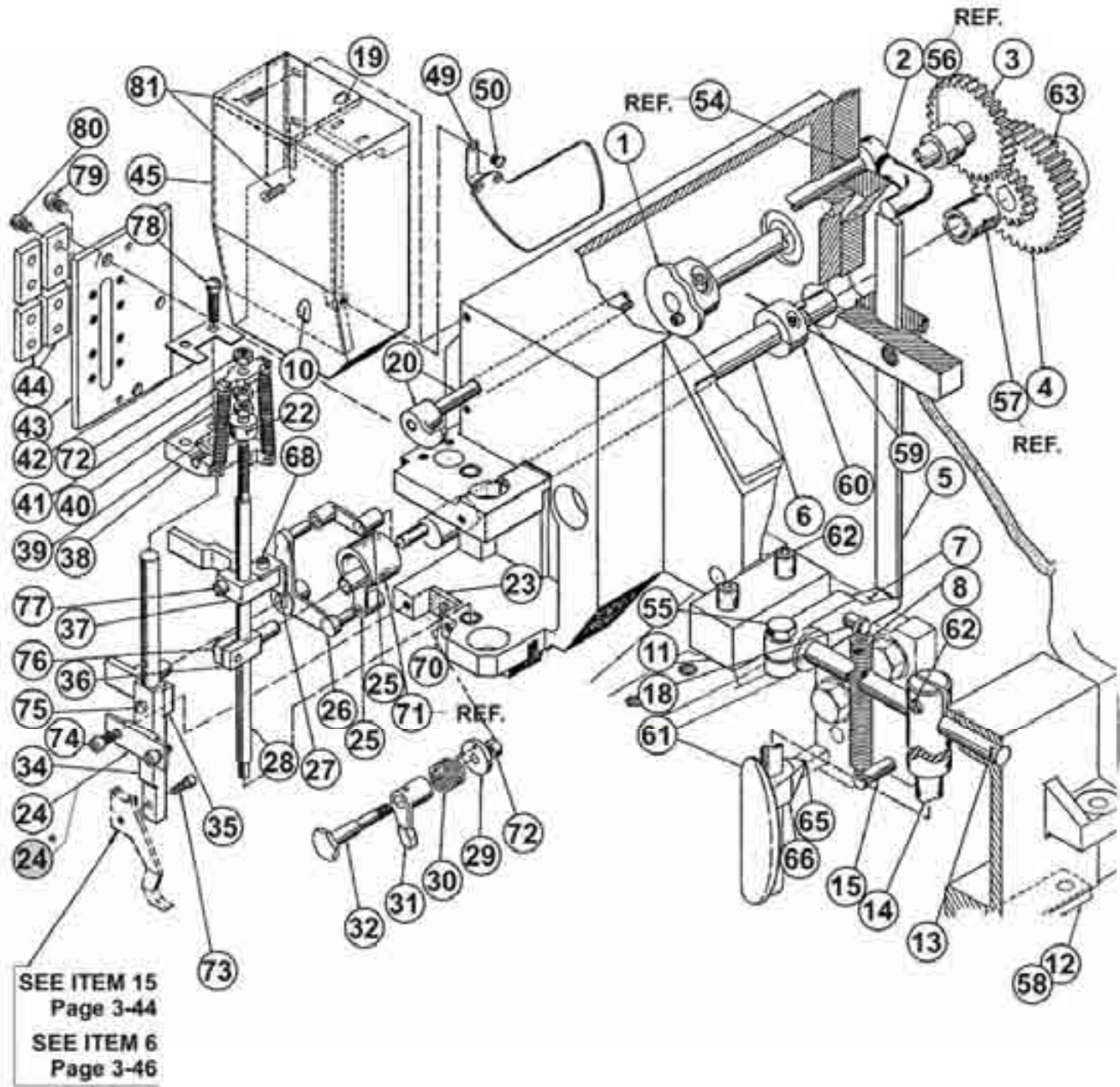

Revised 07/2013

e-mail: service@amfreece.cz; parts@amfreece.cz; website: www.amfreece.com

Phone: +420 582 309 286; Fax: +420 582 360 606

LOWER NEEDLE BAR MECHANISM

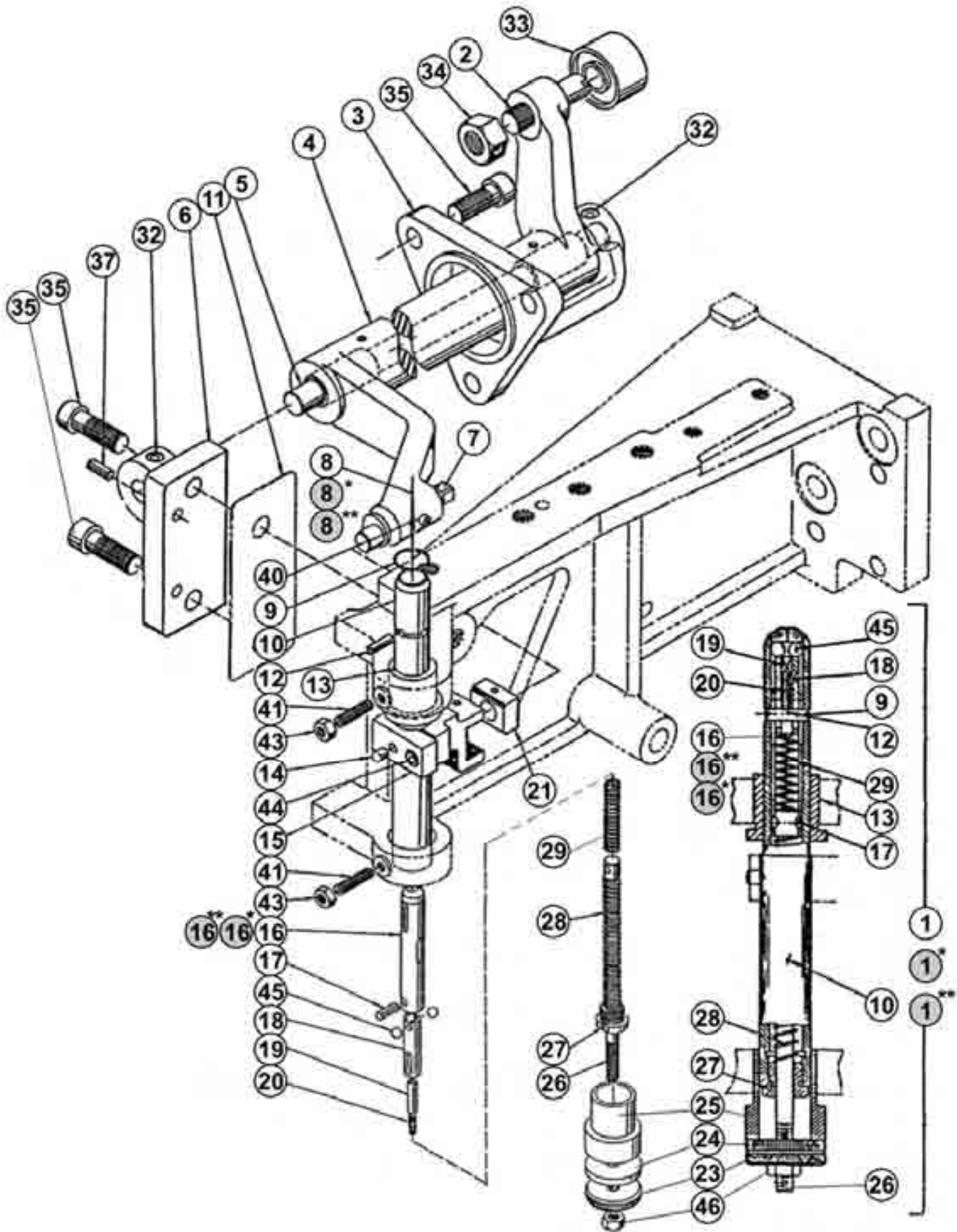

Revised 07/2013

e-mail: service@amfreece.cz; parts@amfreece.cz; website: www.amfreece.com

Phone: +420 582 309 286; Fax: +420 582 360 606

LOWER NEEDLE BAR MECHANISM

DET	PART NUMBER	DESCRIPTION	QTY
01	42531081	Needle Bar Assembly Size 38	1
01*	70.4253.1.078	Needle Bar Assembly Size 28	1*
01**	70.4253.1.079	Needle Bar Assembly Size 49	1**
02	31773015	Rocker Arm Bearing Stud	1
03	35521048	Rocker Arm Bearing	1
04	36691014	Rocker Arm	1
05	31723007	Rocker Arm Pivot	1
06	35521049	Rocker Arm Bearing	1
07	36518030	Bearing Block Stud	1
08	00103238	Round Needle 38	1
08*	00103228	Round Needle 28	1
08**	00103249	Round Needle 49	1
09	35131002	Pin Retainer	1
10	31697003	Needle Bar	1
11	32223045	Shim	1
12	31264001	Stop Pin	3
13	36523022	Small Bushing	1
14	31151001	(Locating Pin) Part of Assem.33441002	1
15	33441002	Lower Clamp, Needle Bar	1
16	35511021	Needle Support Sleeve 38	1
16*	35511081	Needle Support Sleeve 28	1*
16**	35511048	Needle Support Sleeve 49	1**
17	31111009	Sleeve Ext. Conn. Pin	1
18	31566008	Needle Clamp Sleeve	1
19	36771021	Needle Stop	1
20	36531010	Needle Stop Spring	1
21	33182005	Needle Bar Bearing Block	1
23	31593007	Sleeve Adj. Nut	1
24	31412001	Spring Plunger Washer	1
25	36523021	Large Bushing	1
26	31674025	Sleeve Extension	1
27	31695011	Spring Cap	1
28	36532021	Needle Bar Spring	1
29	36532022	Needle Lock Spring	1
32	03100066	Scr. Set Hex.Soc. Cup Pt.# 1/4 - 20 x 5/16	2
33	23231030	Bearing , Ball Part of A 31773015.	1
34	06104001	Nut, Lock "ESNA" # 29 NTE - 54	1
35	01000039	Scr., Hex. Soc. Hd. Cap # 5/16 - 18 x 3/4	5
37	08002028	Pin, Dowel # 3/16 x 7/8	1
40	01002106	Scr., Hex. Soc. Hd. Cap # 10 - 32 x 5/8	1
41	03130001	Scr. Set Hex. Soc. Cone Pt # 8 - 32 x 1/2	2
42			
43	06020019	Nut, Jam Hex.# 8 - 32	2
44	01000013	Scr., Cap. Hex. Soc.# 8 - 32 x 1/2.	1
45	22965006	Ball, Stl. "New Departure" # 11/64	2
46	06002001	Nut, Hex. S. Stl. # 10 - 32	1

* — used on Size 28

** — used on Size 49

Revised 07/2012

e-mail: service@amfreece.cz; parts@amfreece.cz; website: www.amfreece.com

Phone: +420 582 309 246; Fax: +420 582 360 606

LOWER LOOPER AND THREAD DRUM MECHANISM

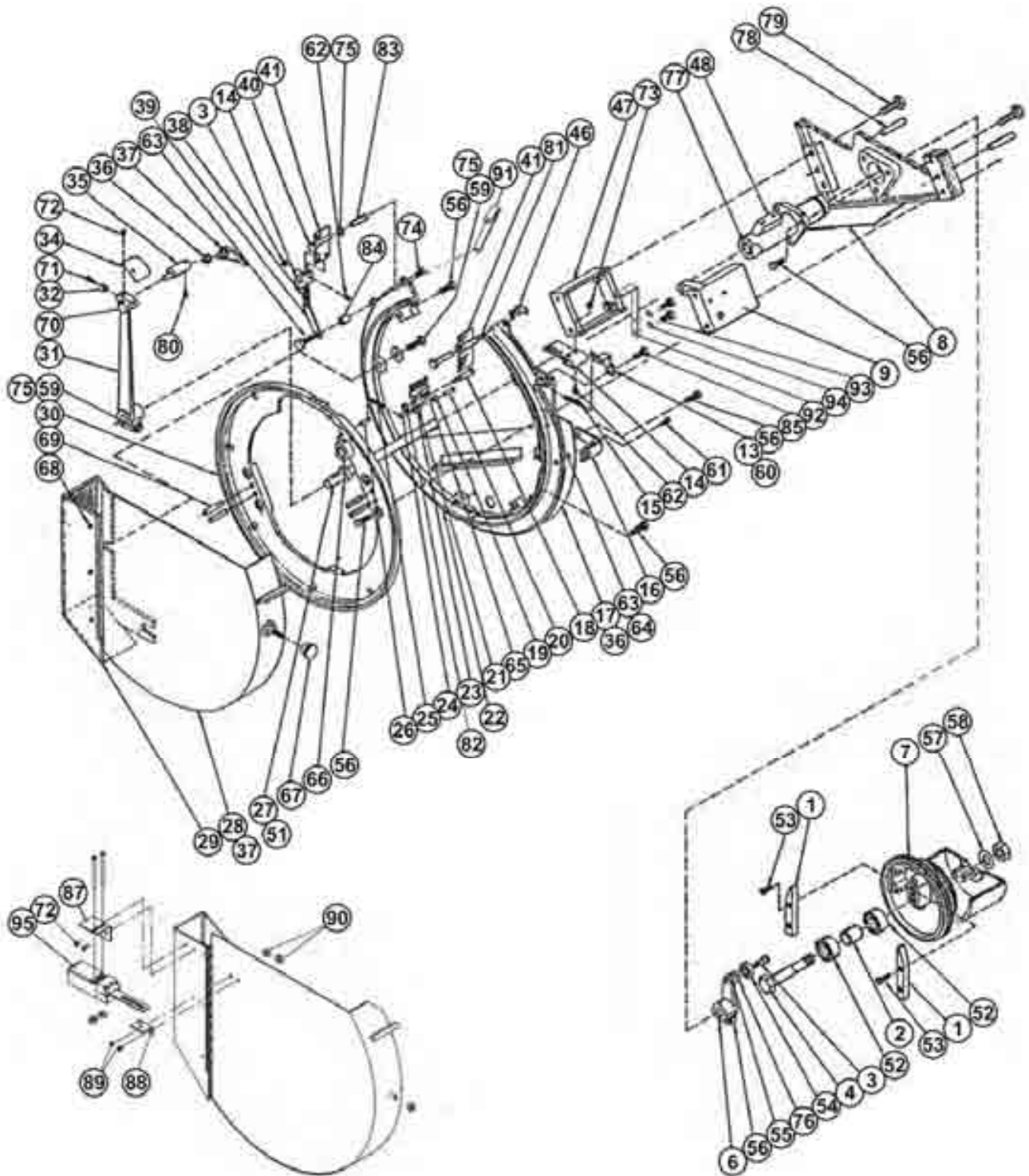

Revised 12/2011

e-mail: service@amfreece.cz; parts@amfreece.cz; website: www.amfreece.com

Phone: +420 582 309 286; Fax: +420 582 360 606

LOWER LOOPER AND THREAD DRUM MECHANISM

DET	PART NUMBER	DESCRIPTION	QTY
01	32533076	Drive Gib	2
02	31464002	Bearing Spacer	1
03	31715005	Bearing Stud	1
04	31845002	Gear Stud	1
05			
06	36651008	Arm Crank	1
07	36271006	Arm Crank Drive Gear	1
08	70.3577.7.042	Crank Guard	1
09	35561001	Tie Bracket (only for DECO 2000 BP)	1
10			
11			
12			
13	34647001	Belt Tightener Arm	1
14	34111085	Belt Spring Fastener	2
15	36542017	Thread Tightener Spring	1
16	34372004	Lock Clip	1
17	35778014	R. S. Drum Cover	1
18	31718025	Brush Cam Lever Stud	1
19	31413030	Cam Roller	1
20	31612051	Roll Stud	1
21	70.3669.1.008	Brush Holder Cam Lever	1
22	35633040	Thread Separator ● ●	1
23	70.3727.4.013	Thread Brush	1
24	31721053	Spring Post	1
25	07.6440.0.050	Lever Spring	1
26	31721054	Spring Post	1
27	31781006	Loop Arm Shaft	1
28	41831082	Drum Cover Assembly	1
29	35812048	Rear Drum Guard	1
30	35633041	Drum ● ●	1
31	36653010	Lower Looper Arm ●	1
32	31572004	Locking Wedge	1
33			
34	34585001	Belt Support	1
35	36518029	Lower Looper Hook Extn.	1
36	36341050	Lower Looper Hook Spacer	1
37	37211018	Lower Hook Assembly	1
38	36543019	Take - Up Spring	1
39	32241004	Take - Up Spring Lever	1
40	31838013	Belt Pulley Stud	2
41	70.3657.2.009	Thread Belt ● ● ●	1
42			
43			
44			
45			
46	37112030	Ass'y., Separator Guide (only for DECO 2000 ATT)	(2)
47	35371004	Drum Rear Tie Bracket	1
48	35541070	Hook Arm Bearing	1
49			
50			

Revised 12/2011

 e-mail: service@amfreece.cz; parts@amfreece.cz; website: www.amfreece.com

Phone: +420 582 309 246; Fax: +420 582 360 606

LOWER LOOPER AND THREAD DRUM MECHANISM

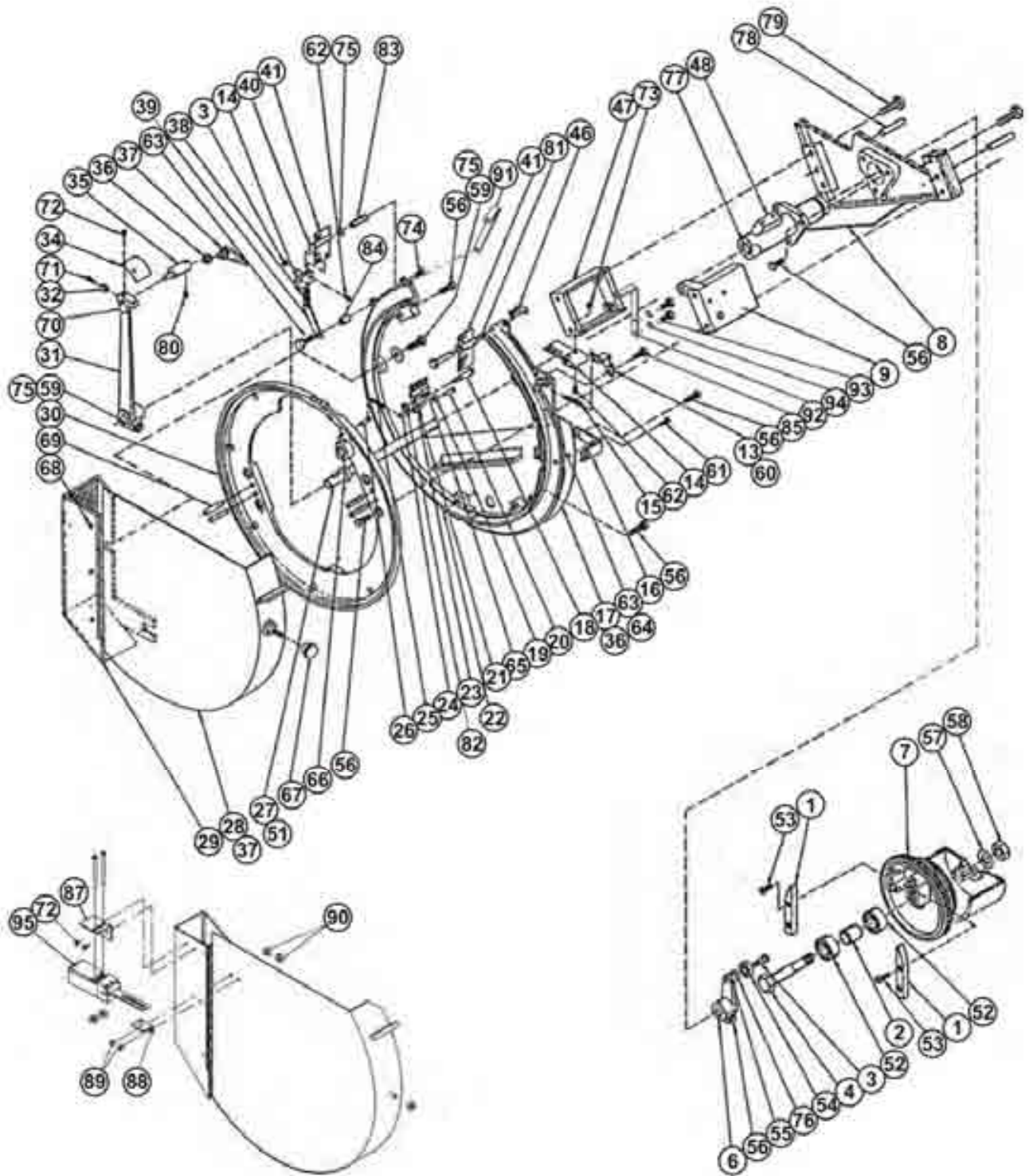

Revised 12/2011

e-mail: service@amfreece.cz; parts@amfreece.cz; website: www.amfreece.com

Phone: +420 582 309 286; Fax: +420 582 360 606

LOWER LOOPER AND THREAD DRUM MECHANISM

DET	PART NUMBER	DESCRIPTION	QTY
51	09020001	Key, Hi - Pro # 1/8 x 5/8	1
52	23231217	Bearing, Ball, * New Depart*# Z 99503	2
53	01000026	Scr., Hex. Soc. Hd. Cap # 1/4 - 20 x 5/8	4
54	23231210	Bearing, Ball, * New Depart*# 77039	1
55	03100013	Scr., Set Hex. Soc. Hd. Cup Pt. # 1/4 - 20 x 3/8	1
56	04200027	Scr., Hex. Hd. # 5/16 - 18 x 1.0	11+(1)
57	07002009	Washer, Flat # 5/8	1
58	06030014	Nut, Hex. # 5/8 - 11	1
59	04200031	Scr. Hex. Hd. # 5/16 - 18 x 1 1/4	3
60	23914009	Hook "S" - Gerwin Corp.# 55 - 3/4	1
61	04100011	Scr. Binding Hd.# 10 - 32 x 3/8	1
62	04100053	Scr. Binding Hd.# 8 - 32 x 5/16	4
63	04202013	Scr.Hex Hd.# 1/4 - 20 x 1 1/4	2
64	06000004	Nut, Hex # 1/4 - 20	3
65	04120005	Scr. Fil.Hd.# 5 - 40 x 3/8	2
66	23161073	Bearing, "Oilite" # FF - 707 - 3	1
67	22967003	Knob w/1/4 - 20 Insert "Reid"# DK - 17	1
68	22914003	Rivet, Stl. # 4 x 580 (500)	3
69	08000016	Pin, Dowel # 3/16 x 3/4	4
70			
71	01002015	Scr. Hex Soc.Hd. Cap # 8 / 32 x 5/8	1
72	01200011	Scr. Hex Soc.But. Hd. Cap # 8 / 32 x 1/4	2
73	06020019	Nut Hex.Jam # 8 - 32	4
74	04000020	Scr.,Flat Hd.# 10 - 32 x 1/2	2
75	07012010	Washer, Flat # 5/16	3+(1)
76	22912066	Plain Washer, S. Stl."SDP" # 9 x 20- 51	1
77	23161095	Bushing,"Oilite" # FF 843 - 2	● ● (2)
78	08000022	Pin, Dowel # 5/16 x 1 1/4	2
79	04200051	Scr., Hex. Soc.Cap # 5/16 - 18 x 1 1/2	4
80	03100012	Scr.,Set Hex. Soc.Cup # 10 - 32 x 1/4	1
81	01200019	Scr.,But.Hd. Hex. Soc. # 6 - 32 x 1/2	1
82	06000002	Nut, Hex. # 10 - 32	1
83	31838014	Bushing Diameter 8 x 35	2
84	31423032	Spacer."RAF"# 1223 - 25 - SS - O -	1
85	04200012	Scr. Hex.Hd. # 1/4 - 20 x 1/2	1
86	17.0004.7.253	Oiler	(1)
87	70.3441.6.045	Switch Holder	1
88	70.3441.6.046	Controller	1
89	01200011	Screw	2
90	06020019	Nut	2
91	70.3288.3.605	Holder	1
92	70.3288.3.604	Holder	1
93	01000002	Screw # 8-32x3/8	2
94	07102007	Spring Washer	2
95	12.0008.4.596	Limit Switch	1
96	71.3271.1.022	Sound Isolation	● ● ● 1
97	71.3271.1.021	Sound Isolation	● ● ● 1
		←	

Revised 12/2011

 e-mail: service@amfreece.cz; parts@amfreece.cz; website: www.amfreece.com

Phone: +420 582 309 246; Fax: +420 582 360 606

MAIN CAM SHAFT ASSEMBLY

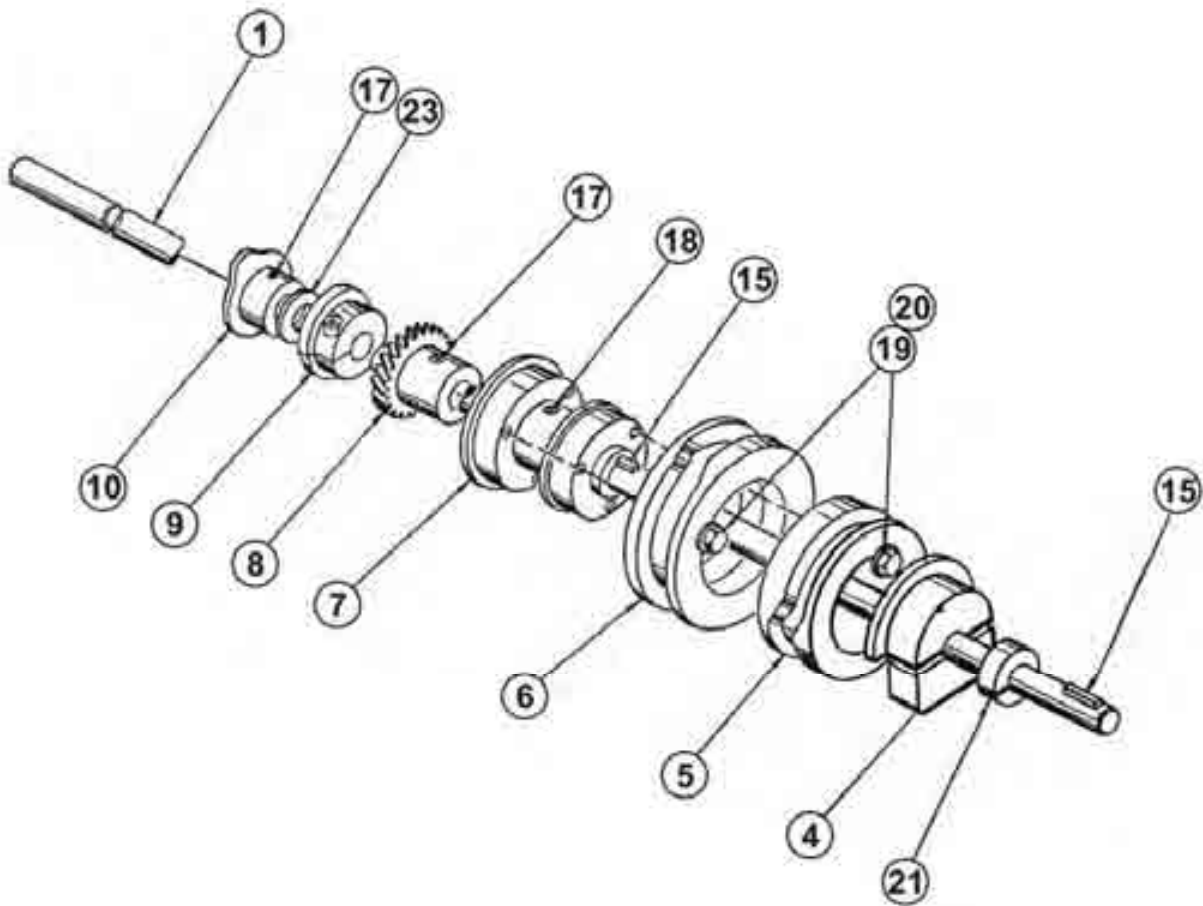

MAIN CAM SHAFT ASSEMBLY

DET	PART NUMBER	DESCRIPTION	QTY
01	31734013	Cam Shaft	1
02			
03			
04	31000008	Flag Assembly	1
05	36513046	Thread Lifter Hook Cam	1
06	36516014	Thread Clamp Cam	1
07	31751004	Clamp Finger Cam Hub	1
08	36223009	Tension Finger Drive Gear	1
09	36514046	Angle Plate Cam (only for DECO 2000 BP)	1
10	36515013	Brush Operating Cam	1
11			
12			
13			
14			
15	09020001	Key, Hi - Pro # 1/8 x 5/8	2
16			
17	03100012	Scr.,Set Hex. Soc.Cup Pt. # 10 - 32 x 1/4	2
18	01.2548.0.000	Scr. Hex. Soc.Cup Pt. # 1/4 - 20 x 1/4	1
19	22911037	Scr.Mach. Cap Pt. # 10 - 32 x 3/8 AN 3 - 3A	2
20	07012001	Washer, Flat # 10	2
21	24117012	Collar, Clamp "Maxwell" # 1/2 I.D. (8 L)	1
22			
23	22912058	Shim, Arbor "SDP" # 7C8 - E 16062	2

Revised 12/2011

e-mail: service@amfreece.cz; parts@amfreece.cz; website: www.amfreece.com

Phone: +420 582 309 246; Fax: +420 582 360 606

THREAD GRIPPER & ELEVATOR MECHANISM

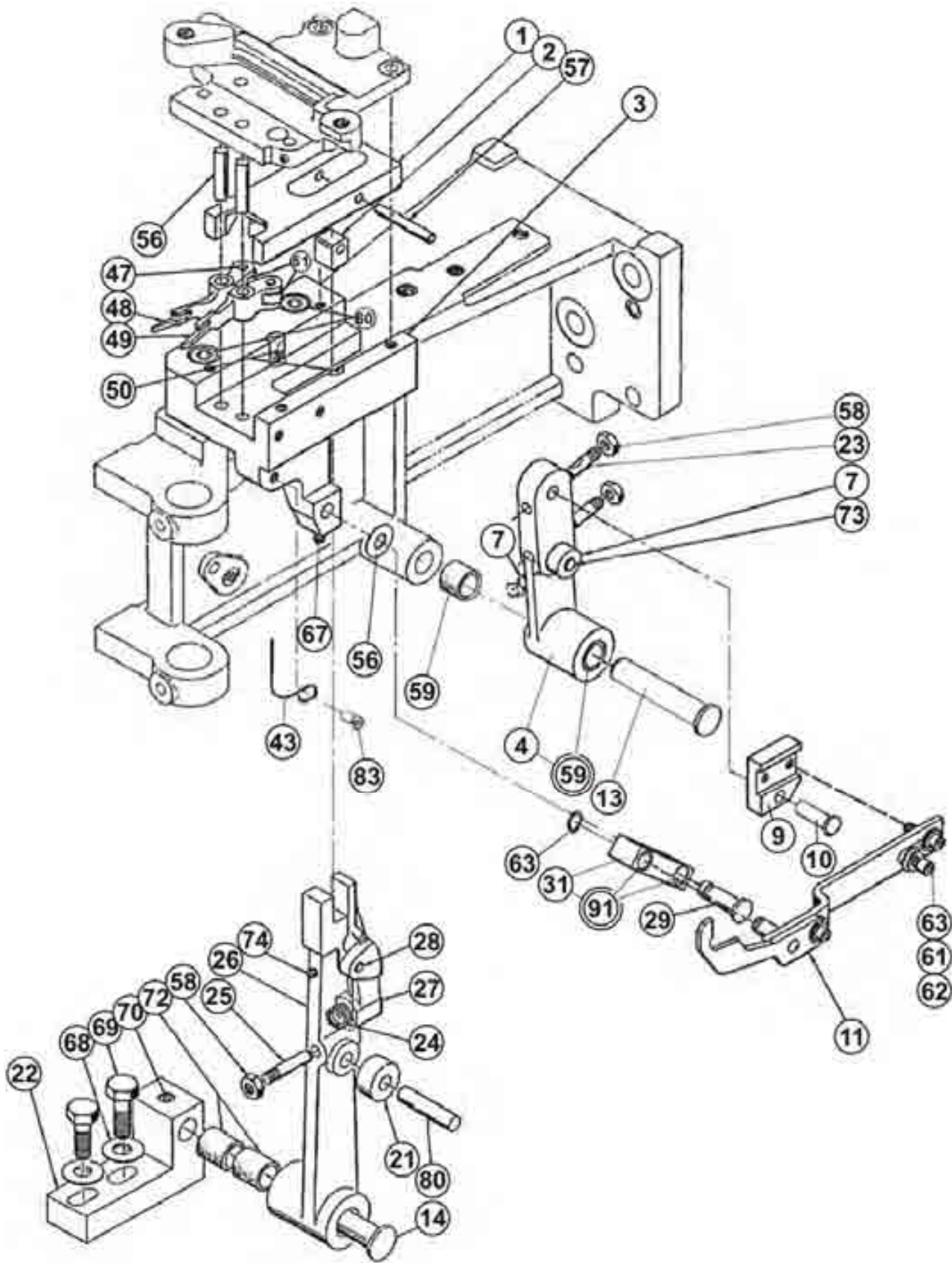

Revised 12/2011

e-mail: service@amfreece.cz; parts@amfreece.cz; website: www.amfreece.com

Phone: +420 582 309 286; Fax: +420 582 360 606

THREAD GRIPPER & ELEVATOR MECHANISM

DET	PART NUMBER	DESCRIPTION	QTY
01	33257001	Clamp Finger Cam Slide	1
02	32434001	Thread Clamp Pivot Block	1
03	35551002	Thread Clamp Finger Brkt.	1
04	36661001	Thread Lifter Hook Cam Lever	1
07	31413031	Cam Roller	1
09	33244009	Hook Adjust Block	1
10	31611010	Cam Lever Stud	1
11	70.3721.1.153	Lifter Hook Assembly	1
13	31641015	Cam Lever Stud	1
14	31641019	Cam Lever Stud	1
16			
17			
19			
21	31423068	Cam Roller	1
22	36613038	Clamp Pivot Bracket	1
24	36532025	Clamp Finger Lever Spring	1
25	31288023	Clamp Stud	3
26	36673028	Clamp Finger Lever	1
27	36647001	Spring Piece	1
28	31215008	Piece Pin	1
29	31641010	Thread Hook Lifter Lever Stud	1
31	33334012	Thread Hook Lifter Lever	1
43	70.3282.7.100	Divider	
47	31112002	Roller Pin	2
48	70.3664.5.007	Rear Finger	1
49	70.3664.5.006	Front Finger	1
50	32121004	Slide Wick Oiler	2
51	31413029	Cam Roller	2
56	08000044	Pin Dowel # 3/16 Dia x 1	2
57	08000109	Pin Dowel # 5/32 x 1	1
58	06000002	Nut # 10 - 32	2
59	01.7305.0.900	Bearing	(2)
60	01000047	Scr. Hex. Soc. Hd. Cap # 5/16 - 18 x 1	2
61	07012005	Washer, Flat # 8	2
62	07102007	Washer, Lock Spring # 8	2
63	25379218	Ring Retainer # 5100 - 25 (1/4)	1
65	01000002	Scr. Hex. Soc. Hd. Cap # 8 - 32 x 3/8	2
67	03100012	Scr.Set Hex. Soc. Cup Pt. # 10 - 32 x 1/4	1
68	07012002	Washer Flat # 1/4	2
69	01000037	Scr. Hex. Hd. # 1/4 - 20 x 1.0	2
70	03100066	Scr.Set Hex. Soc. Cup Pt. # 1/4 - 20 x 5/16	2
72	23132142	Bearing " Oilite " # AA - 521 - 1	2
73	08000110	Pin, Dowel # 7/32 Dia x 5/8	1
74	03140003	Scr.Set Hex. Soc. Oval Pt. # 8 - 32 x 3/8	1
80	08000007	Pin, Dowel # 1/4 Dia x 1.0	1
83	04100054	Screw #8-32	1
91	23132056	Bearing	(2)

Revised 12/2011

 e-mail: service@amfreece.cz; parts@amfreece.cz; website: www.amfreece.com

Phone: +420 582 309 246; Fax: +420 582 360 606

PICK STITCH & TENSION FINGER

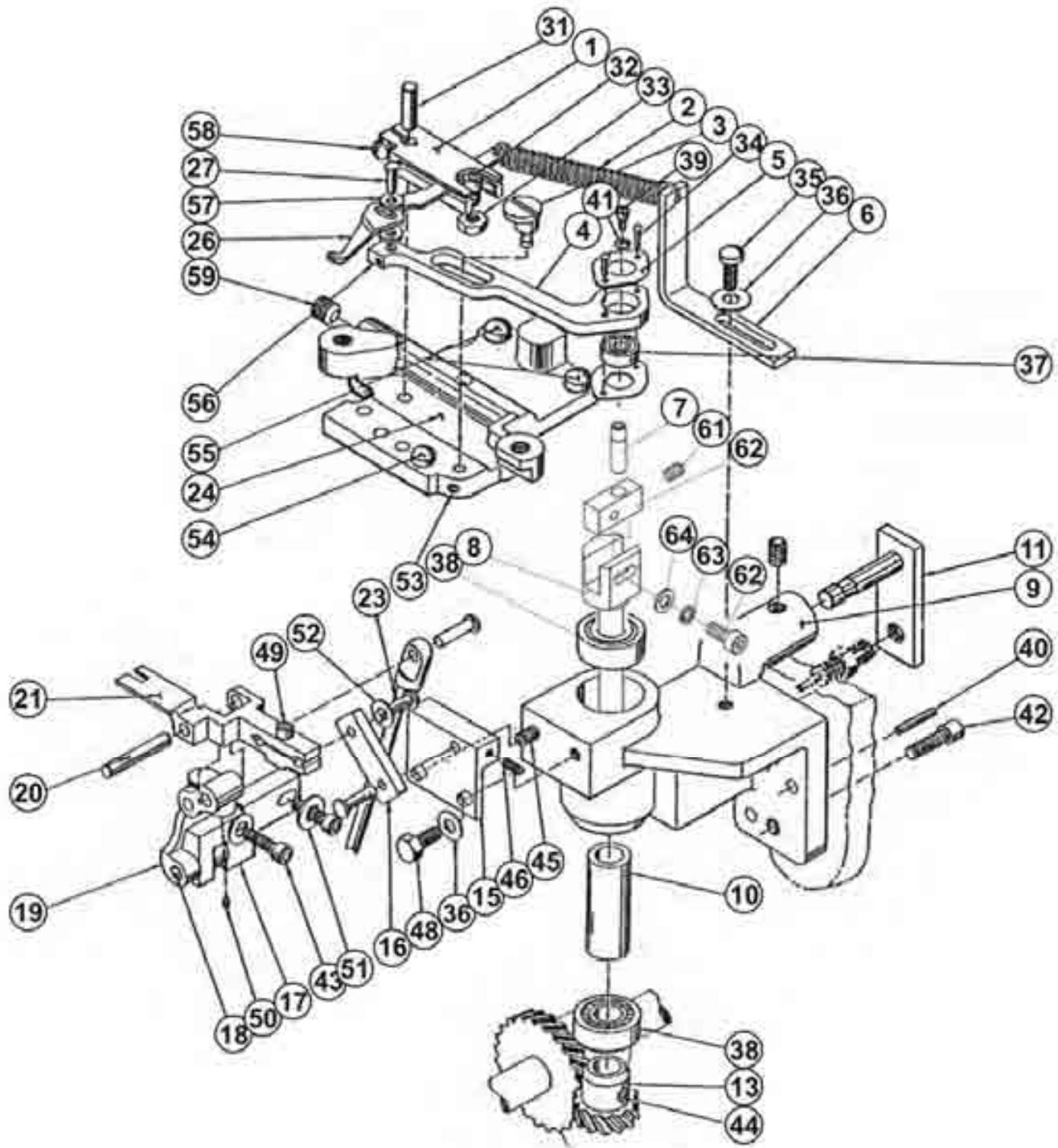

PICK STITCH & TENSION FINGER

DET	PART NUMBER	DESCRIPTION	QTY
01	35511045	Support Block	1
02	36542018	Finger Spring	1
03	36518027	Stud Eccentric	1
04	35526005	Slide Support	1
05	32691001	Ball Bearing Retainer	2
06	34372042	Finger Spring Tension Holder	1
07	70.3651.8.022	Support Stud	1
08	70.3651.8.020	Eccentric Shaft	1
09	35542007	Tension Finger Ball Bearing Bracket	1
10	31426015	Bearing Spacer	1
11	31000009	Sensor Holding Assembly	1
12			
13	36221009	Driven Gear	1
14			
15	33252029	Pusher Plate	1
16	32643073	Link (Pick Stitch)	1
17	33258075	Plate Bracket Pivot Arm Support	1
18	31721022	Lower Finger	1
19	36677016	Pivot, Arm	1
20	31215012	Bracket Pin	1
21	36691021	Bender Plate	1
22			
23	31612045	10 - 6 Cam Roller Stud	3
24	35815007	Bracket Cover	1
25			
26	37211131	Thread Tension Finger	1
27	31611064	10 - 1 Plain Stud	1
28			
29			
30			
31	08000015	Pin, Dowel #3/16 Dia x 5/8 Lg	1
32	01000058	Scr., Hex. Soc. Hd. Cap # 8 - 32 x 3/16	1
33		Nut, Square # 8 - 32	1
34	08504001	Rivet, Rd. Hd. (Alum.) # 1/16 x 5/16	2
35	04120002	Scr., Fill. Hd. # 10 - 32 x 3/8	1
36	07012001	Washer, Flat # 10	2
37	23231040	Bearing, Ball "New Depart" # 77 R 3	1
38	23231226	Bearing	2
39	01000005	Scr., Hex. Soc. Hd. Cap # 6 - 32 x 1/4	1
40	08000044	Pin, Dowel # 3/16 x 1.0	2
41	07102007	Washer, Lock # 8	1
42	01000047	Scr., Hex. Soc. Hd. Cap # 5/16 - 18 x 1.0	1
43	01002015	Scr., Hex. Soc. Hd. Cap # 8 - 32 x 5/8	2
44	03100154	Scr., Hex. Soc. Hd. Cup Pt. # 10 - 32 x 3/16	2
45	03102026	Scr., Hex. Soc. Hd. Cup Pt. # 10 - 32 x 1/2	1
46		Scr., Hex. Soc. Flat Pt. # 8 - 32 x 1/4	1
47			
48	04200039	Scr., Hex. Hd. # 10 - 32 x 3/8	1
49	01000027	Scr., Cap Hex. Soc. # 6 - 40 x 3/8	1
50	03101038	Scr., Set Self lock Knurl. Cup # 6- 40 x 1/4	1

Revised 12/2011

 e-mail: service@amfreece.cz; parts@amfreece.cz; website: www.amfreece.com

Phone: +420 582 309 246; Fax: +420 582 360 606

PICK STITCH & TENSION FINGER

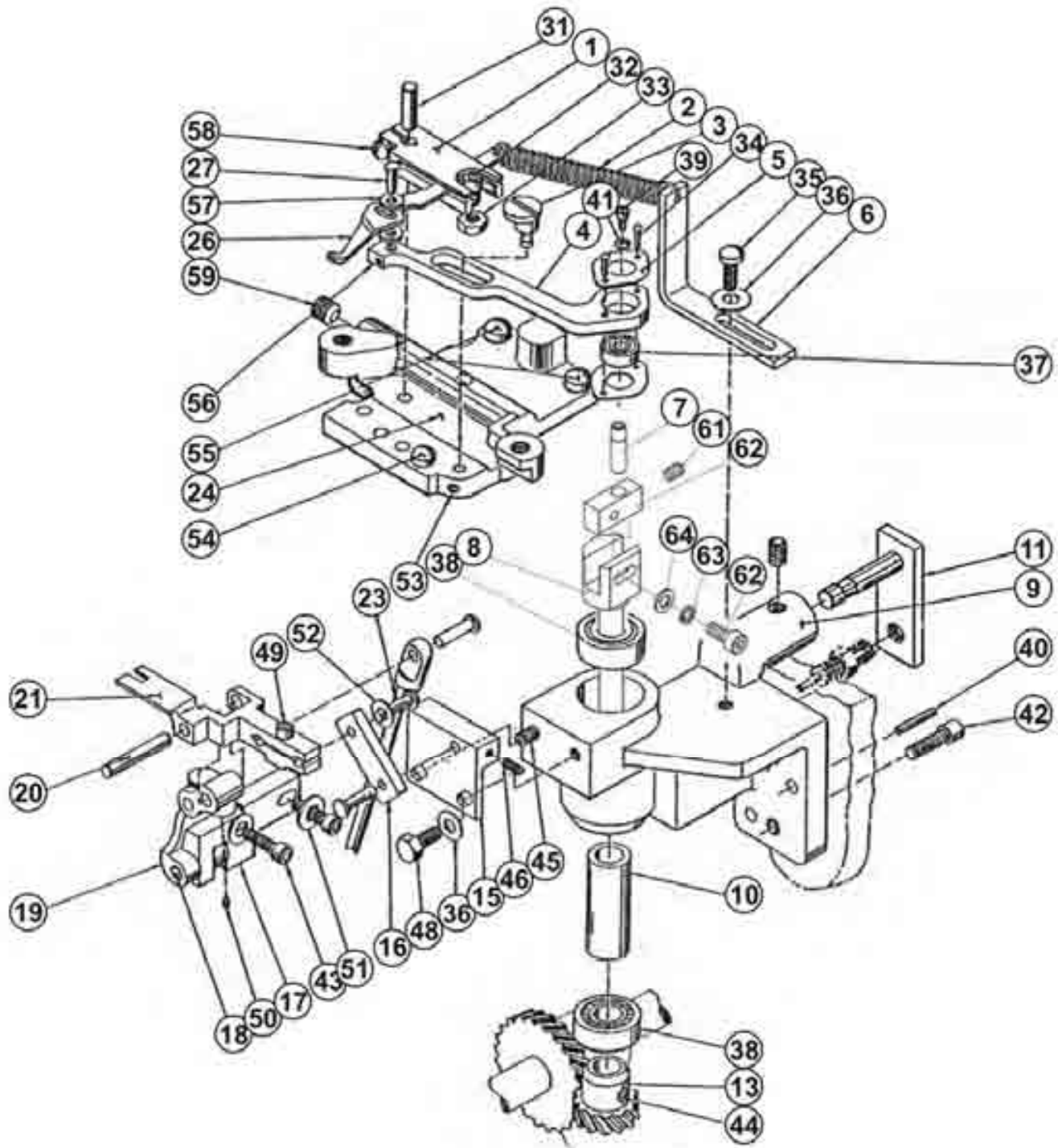

TENSION FINGER ASSEMBLY

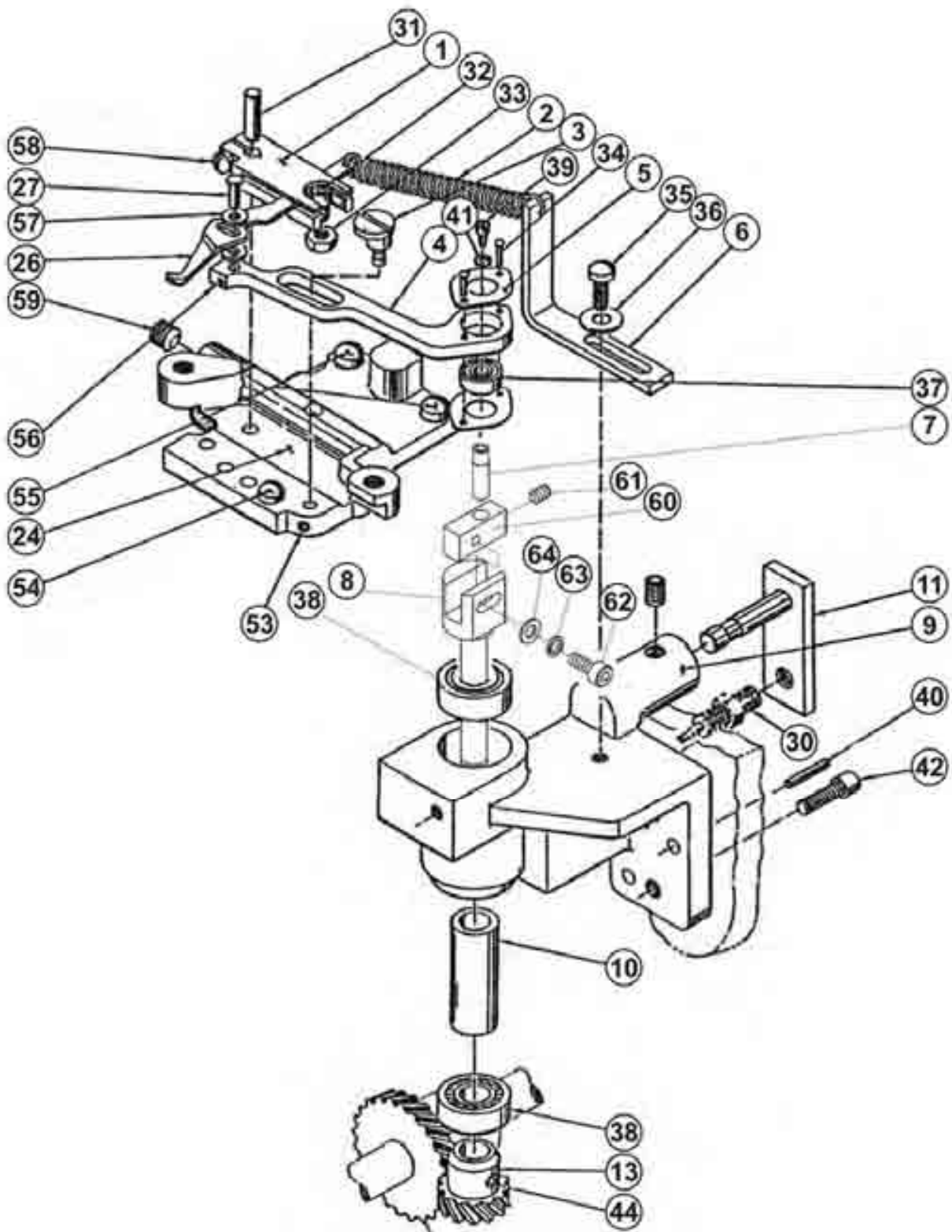

Revised 12/2011

e-mail: service@amfreece.cz; parts@amfreece.cz; website: www.amfreece.com

Phone: +420 582 309 286; Fax: +420 582 360 606

TENSION FINGER ASSEMBLY

DET	PART NUMBER	DESCRIPTION	QTY
01	35511045	Support Block	1
02	36542018	Finger Spring	1
03	36518027	Stud Eccentric	1
04	35526005	Slide Support	1
05	32691001	Ball Bearing Retainer	2
06	34372042	Finger Spring Tension Holder	1
07	70.3651.8.022	Support Stud	1
08	70.3651.8.020	Eccentric Shaft	1
09	35542007	Tension Finger Ball Bearing Bracket	1
10	31426015	Bearing Spacer	1
11	31000009	Sensor Holding Assembly	1
12			
13	36221009	Driven Gear	1
24	35815007	Bracket Cover	1
25			
26	37211131	Thread Tension Finger	1
27	31611064	10 - 1 Plain Stud	1
28			
29			
30	12.0008.3.244	Sensor	1
31	08000015	Pin, Dowel # 3/16 Dia. X 5/8 Lg.	1
32	01000058	Scr., Hex. Soc.Hd. Cap. # 8 - 32 x 3/16	1
33	06000003	Nut, Mach. Scr. Hex. # 8 - 32	1
34	08504001	Rivet, Rd. Hd. (Alum.) # 1/16 x 5/16	2
35	04120002	Scr., Fil. Hd. # 10 - 32 x 3/8	1
36	07012001	Washer, Flat # 10	1
37	23231040	Bearing, Ball "New Depart" # 77 R 3	1
38	23231226	Bearing	2
39	01000005	Scr., Hex. Soc.Hd. Cap. # 8 - 32 x 1/4	1
40	08000044	Pin, Dowel # 3/16 x 1.0	1
41	07102007	Washer, Lock # 8	1
42	01000047	Scr., Hex. Soc.Hd. Cap. # 5/16 - 18 x 1.0	1
43			
44	03100154	Scr., Set Hex. Soc.Cup.Pt. # 10 - 32 x 3/16	1
45			
46			
47			
53	03100038	Scr., Set Hex. Soc.Cup. # 5 - 40 x 3/16	1
54	04120012	Scr., Fil. Hd. # 8 - 32 x 5/16	1
55	04120001	Scr., Fil. Hd. # 8 - 32 x 1/2	2
56	03100147	Scr., Set Hex. Soc.Cup.Pt. # 6 - 40 x 3/16	1
57	07016002	Washer, Flat (Brass) # 5	2
58	04120004	Scr., Fil. Hd. # 8 - 32 x 3/8	1
59	03100008	Scr., Set Hex. Soc.Cup.Pt. # 1/4 - 20 x 1/4	1
60	70.3651.8.021	Holder	1
61	08.6400.4.005	Screw M4x5	
62	08.6000.4.010	Screw M4x10	
63	08.6802.4.000	Spring Washer 4,1	
64	08.6852.4.000	Washer 4,3	

Revised 12/2011

 e-mail: service@amfreece.cz; parts@amfreece.cz; website: www.amfreece.com

Phone: +420 582 309 246; Fax: +420 582 360 606

MATERIAL FEED

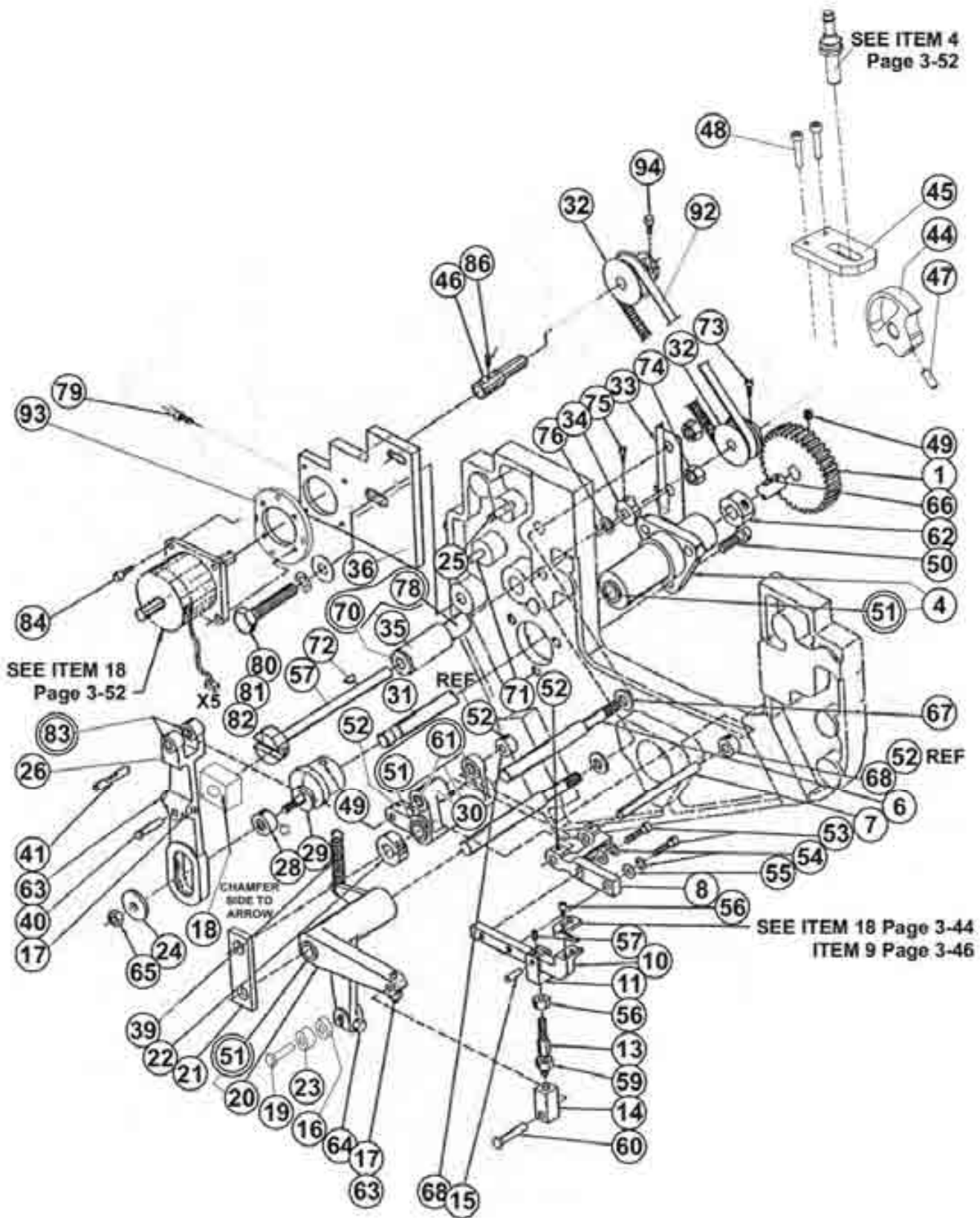

MATERIAL FEED

DET	PART NUMBER	DESCRIPTION	QTY
01	36226011	Material Feed Drive Gear ●●●	1
02			
03			
04	31881004	Material Feed Drive Shaft Bearing	1
05			
06	31773013	Feed Motion Brkt. Shaft	2
07	31217001	Material Feeder Arm Support Bracket Shaft	1
08	35523018	Material Feeder Support Bracket	1
09			
10	36613034	Material Feeder Arm	1
11	32739004	Material Feeder Arm Flt. Fork	1
12			
13	31852015	Feeder Lifter Rod	1
14	32428002	Feeder Lifter Rod Hd.	1
15	31215002	Lifter Fork Pin	1
16	08.6852.6.000	Washer	1
17	31288023	Clamp Stud	2
18	70.3142.3.070	Guide Block	1
19	31612052	Cam Roller Stud	1
20	36691022	Feeder Lifter Bell Crank	1
21	32225017	Shaft Support Plate	1
22	31511015	Feed Mtn. Bracket Shaft Collar	1
23	23231045	Bearing	1
24	31421005	Feed Mtn. Ecc. Stud Washer	1
25	31721039	Post, Spring	1
26	36667012	Feed Eccentric Arm	1
27			
28	36344057	Feed Motion Cam roller	1
29	36515020	Material Feed Cam	1
30	36678019	Feed Motion Bracket	1
31	31728003	Material Feed Drive Shaft	1
32	70.3634.3.063	Pulley Stitch Adj. Shaft Drive	2
33	70.3462.7.067	Limit Stop Plate	1
34	36771079	Slide Block Limit Stop	1
35	35225010	Slide Bearing Block	1
36	31000006	Motor Mounting Bracket ●	1
37	31644004	Stitch Adj. Slide Block	1
38			
39	36546024	Ext. Spring	1
40	08000007	Pin Dowel #1/4 x 1	1
41	31215079	Feed Motion Bracket Pin	1
42			
43			
44	31000018	Home Sensor Cam	1
45	70.3100.0.020	Sensor Mtg. Plate	1
46	70.3100.0.043	Extension Shaft	1
47	03102026	Screw	1
48	08.6000.4.020	Screw	2
49	03100013	Scr., Set Hex. Soc.Cup.Pt. # 1/4 - 20 x 3/8 III →	2
50	04200030	Scr., Hex.Hd.Cap # 5/16 - 18 x 3/4	1

Revised 12/2011

 e-mail: service@amfreece.cz; parts@amfreece.cz; website: www.amfreece.com

Phone: +420 582 309 246; Fax: +420 582 360 606

MATERIAL FEED

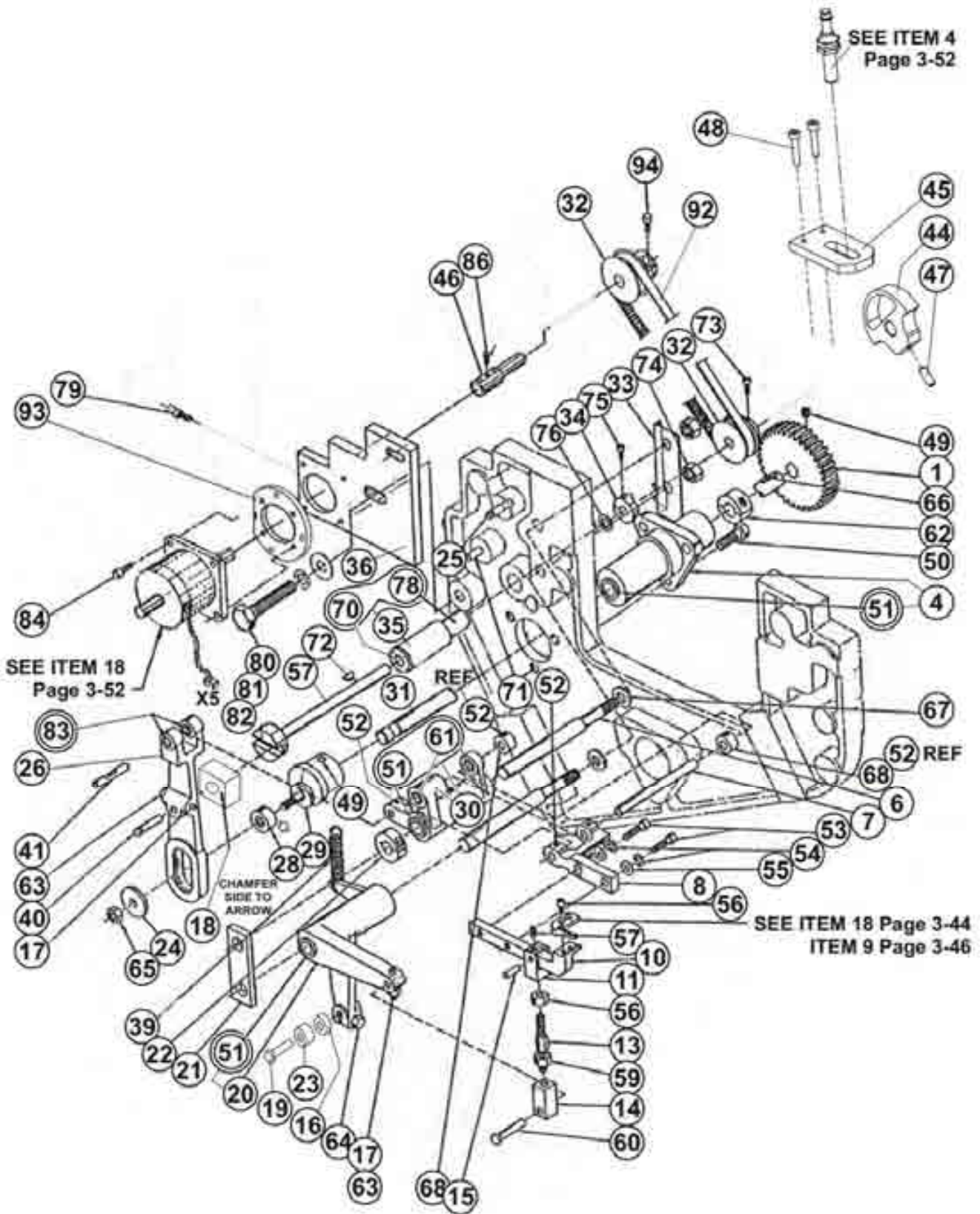

MATERIAL FEED

DET	PART NUMBER	DESCRIPTION	QTY
51	23161073	Bushing "Oilite" #FF - 707 - 3 ● ●	(6)
52	03100051	Scr., Set Hex. Soc. Cup. Pt. # 8 32 x 1/8	3
53	01000019	Scr., Hex. Soc. Hd. Cap. # 10 - 32 x 3/4	1
54	07100011	Washer, Lock #10	2
55	07012001	Washer, Flat # 10	2
56	01000059	Scr., Hex. Soc. Hd. Cap. # 6 - 40 x 1/4	1
57	03100012	Scr., Hex. Soc. Cup. Pt. # 10 - 32 x 1/4	1
58	06020004	Nut. Hex. Jam # 1/4 - 20	1
59	06020021	Nut. Hex. Jam L. H. # 1/4 - 20	1
60	31612054	Stud, Cam Roller # 10 - 6 - 1A1 - 67	1
61	23132122	Bearing "Oilite" # AA - 520 - 8 ● ●	3
62	24117012	Collar "Holokrome" # 15014	1
63	06000002	Nut. Hex # 10 - 32	1
64	04200011	Scr., Hex. Hd. # 10 - 32 x 5/8	1
65	06000005	Nut. Hex # 1/4 - 28	1
66	09020001	Key, Hi - Pro # 1/8 x x 5 /8	1
67	22912090	Washer "Reid's " H. Duty # FW - 3	2
68	01.7435.1.000	Collar	2
69			
70	23161048	Bushing "Oilite" # FF - 607 - 3 ● ●	(1)
71	08000044	Pin. Dowel # 3/16 x 1	1
72			
73	01000013	Scr., Hex. Soc. Hd. Cap # 8 - 32 x 1/2	2
74	06000014	Nut. Hex # 3/8 - 16	2
75	01000017	Scr., Hex. Soc. Hd. Cap # 6 - 32 x 3/8	1
76	23181235	Bearing, Thrust "Rulon" # DRT 0612 - 2	1
77			
78	23132155	Bushing "Oilite" # AA - 507 - 2 ● ●	(1)
79	01000026	Scr. H. S. H. C. # 1/4 - 20 x 5/8	1
80	04200046	Scr., Hex. Hd. # 3/8 - 16 x 2	1
81	07100009	Washer, Spring Lock # 3/8	1
82	07012003	Washer, Flat # 3/8	1
83	23161008	Bearing "Oilite" # FF - 303 ● ●	(2)
84	01000056	Scr., Hex. Hd. Cap # 10 - 24 x 1/2	4
85	03102026	Scr., Set Hex. Soc. Cup Pt. # 10 - 32 x 1/2	1
86	08.6400.4.008	Screw M 4 - 8	3
87			
88			
89			
90			
91			
92	12.5050.2.029	Belt Timing ● ● ●	1
93	70.3100.0.040	Motor Flange	1
94	08.6000.4.010	Screw M 4 - 10	4



Revised 12/2011

e-mail: service@amfreece.cz; parts@amfreece.cz; website: www.amfreece.com

Phone: +420 582 309 246; Fax: +420 582 360 606

ANGLE STITCH MECHANISM

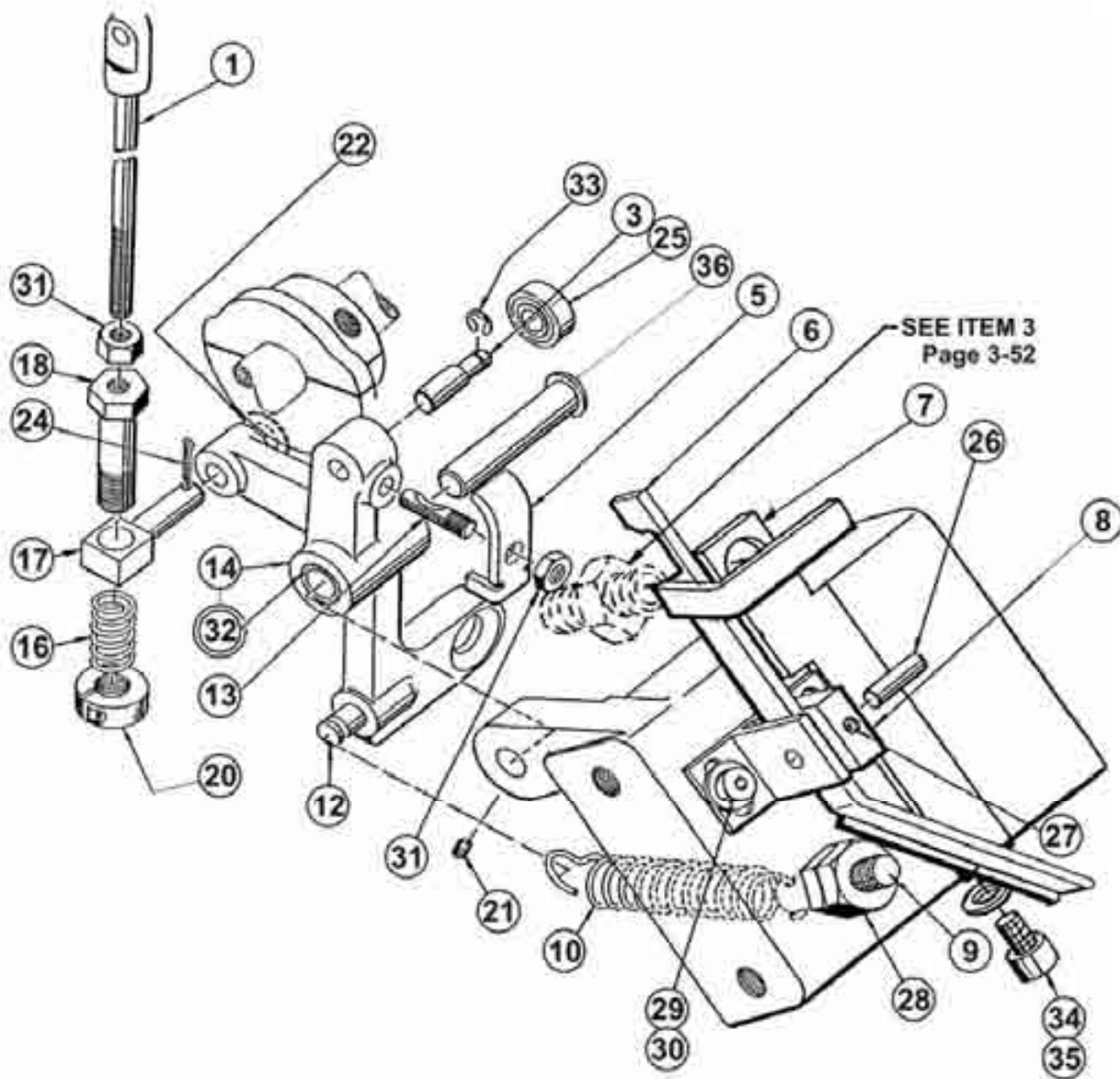

UPPER LOOPER

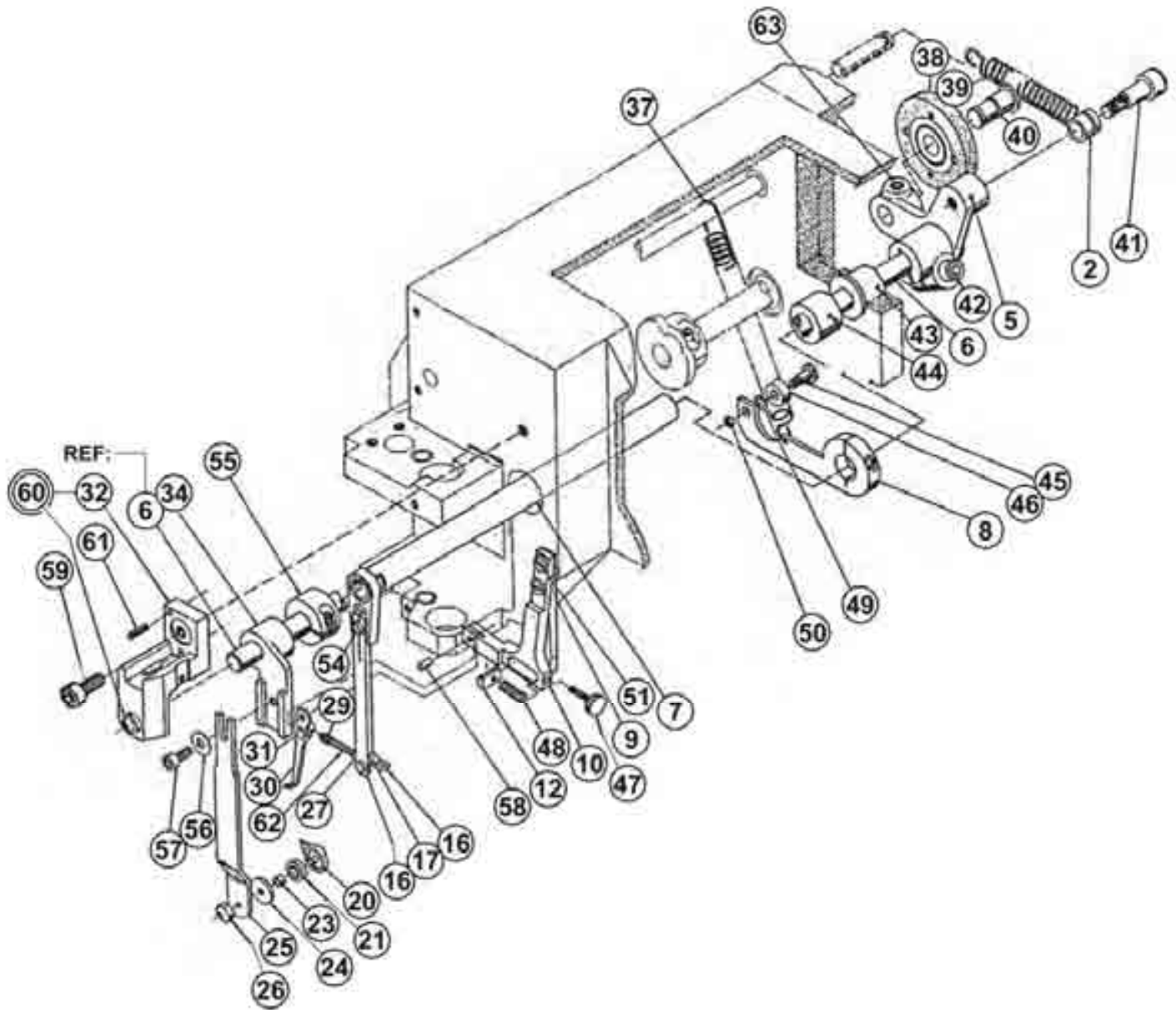

UPPER LOOPER

DET	PART NUMBER	DESCRIPTION	QTY
01			
02	31722031	Sleeve	1
03	70.3126.8.002	Looper Arm Shaft Assembly	1
04	08.6400.4.005	Pin	1
05	36691024	Cam Lever	1
06	31268001	Left Upper Looper Arm Shaft	1
07	70.3676.1.032	Ass'y., Top Right Looper Shaft	1
08	70.3661.3.100	Ass'y., Right Upper Looper Cam Lever	1
09	34378066	Knob Stop	1
10	33251105	Finger Support	1
11	70.3165.1.019		
12	31211015	Arm Stop	1
13			
14			
15			
16	31955003	Pusher Rod	1
17	31644003	Bearing Stud	1
18	32542111	Pusher Rod Arm	1
19			
20	37231028	Upper Looper Knife	1
21	36341035	Looper Roller	1
22			
23	31413002	Stud Spacer	1
24	70.3149.1.001	Left Looper Roller Seat	1
25	70.3662.5.002	Left Upper Looper Arm	1
26	31815017	Left Upper Looper Nut	1
27	31413001	Finger Pusher Rod Collar	1
28			
29	31593001	Adj. Nut	1
30	37211045	Right Looper Finger	1
31	31613035	Rod Support	1
32	35521118	Bearing Bracket	1
33			
34	35511040	Left Upper Looper Bracket	1
35			
36			
37	36546022	Spring	1
38	42241009	Cam Roller Assembly	1
39	12.3011.0.006	Cam Lever Spring	1
40	31741013	Cam Roller	1
41	01300037	Scr., Shldr. Hex. Soc. # 5/16 Dia x 5/8 Lg.	1
42	01000093	Scr., Hex. Soc. Hd. Cap. # 1/4 - 20 x 3/4	1
43	23132178	Bearing "Oilite" # AA -630 -1	1
44			
45	01300029	Scr. Shldr. Hex. Soc. Hd. # 1/4 Dia x 1/4 Lg.	1
46	23231045	Bearing "New Depart" # 77 R 4	1
47	70.3121.1.016	Knurled Knob Scr. "Shearloc" # 8 - 32 x 1.0 Gy	1
48	24971056	Spring, Comp., "Lee" # LC - 032 C - 8	1
49	07106001	Washer, Lock Hi Collar # 1/4	1
50	06220001	Nut, Flex Loc. Hex. # 21 FK - 1024	1

Revised 12/2011

 e-mail: service@amfreece.cz; parts@amfreece.cz; website: www.amfreece.com

Phone: +420 582 309 246; Fax: +420 582 360 606

UPPER LOOPER

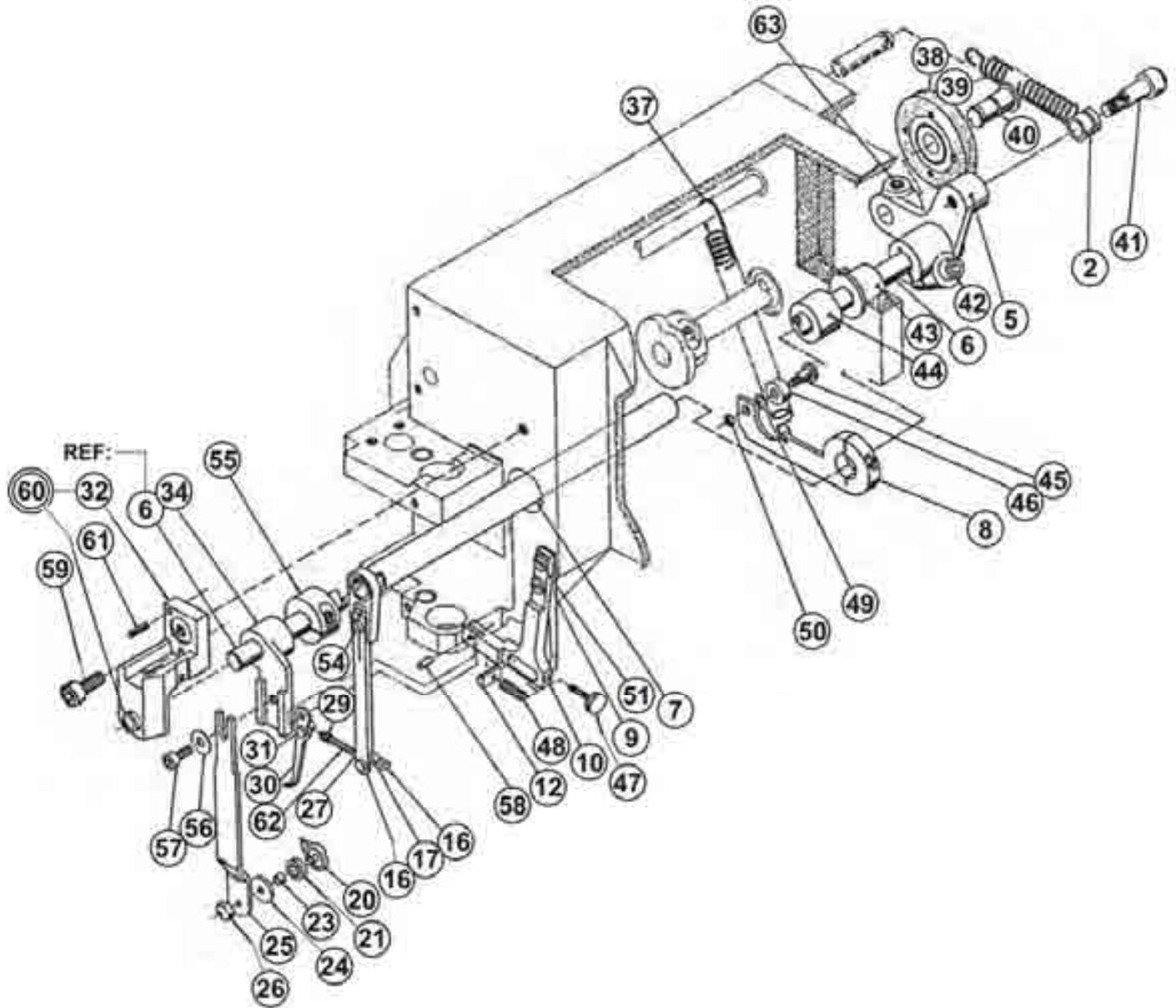

WORK PLATE ASSEMBLY

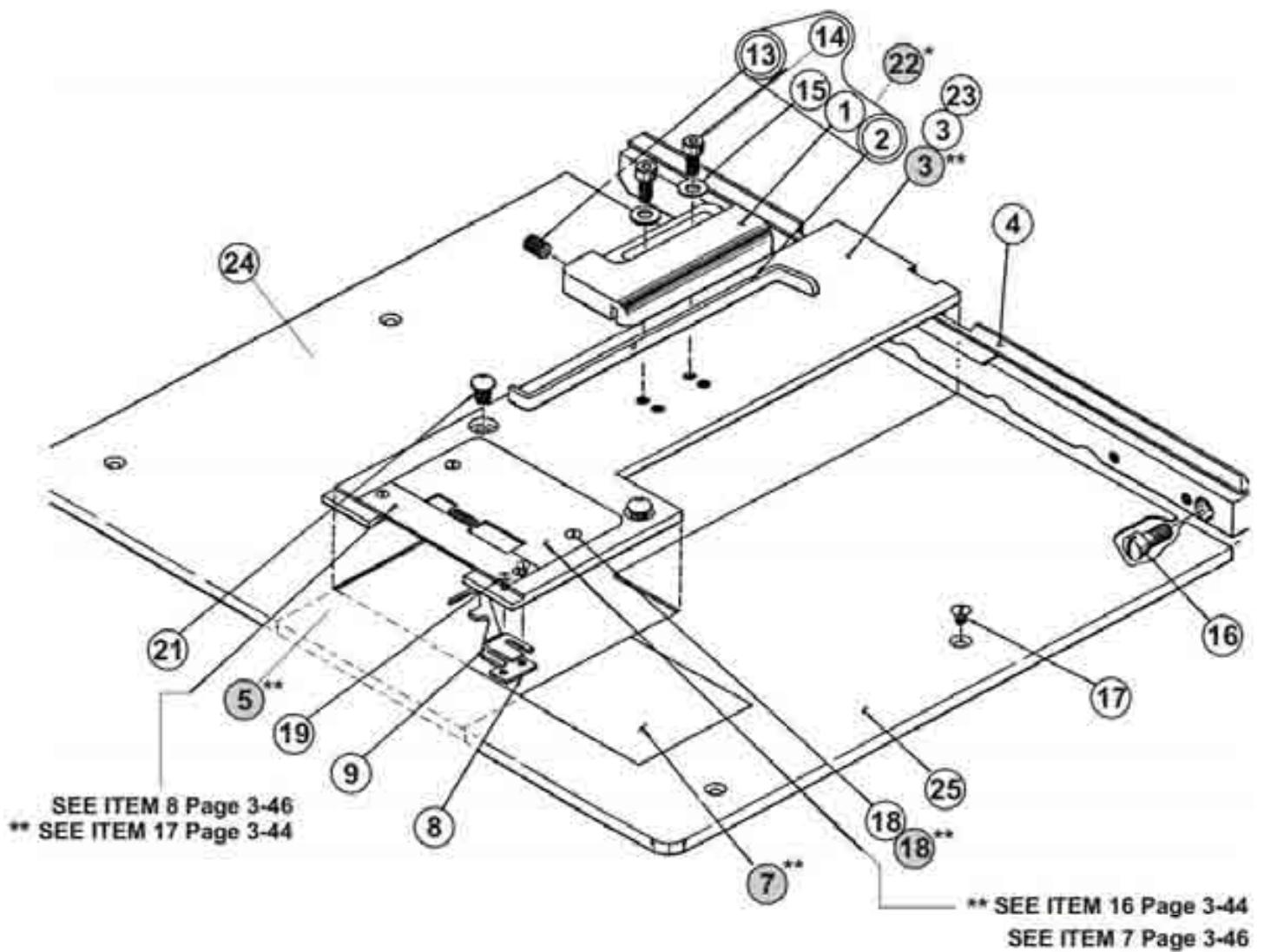

* EXTRA PARTS

** PICK STITCH

WORK PLATE ASSEMBLY

DET	PART NUMBER	DESCRIPTION	QTY
01	36741109	Slide Material Gauge	(1)
02	37771022	Rod Material Gauge - Assembly	(1)
03**	33258076	Throat Plate Holder	1
03	70.3325.8.077	Throat Plate Holder	
04	70.3542.1.065	Table Rest	1
05**	70.3541.1.112	Metal Table	1
06			
7**	35411121	Acces Plate - Assembly	1
08	32233001	Clamp Strip	1
09	37211133	Thread Guide Finger	1
10			
11			
12			
13	22966116	Plunger, Ball "Vlier" # BL - 54 N	(1)
14	01000032	Scr., Hex. Soc.HD. Cap # 10 - 32 x 3/8	(2)
15	07012001	Washer, Flat # 10	(2)
16	04120070	Scr., Fol. Hd. # 1/4 - 20 x 1/2	2
17	04002109	Scr., Flat. Hd.(S. Stl.) # 8 - 32 x 1/4	4
18	04002086	Scr., Flat. Hd.(S. Stl.) # 5 - 40 x 1/4	2
18**	04002086	Scr., Flat. Hd.(S. Stl.) # 5 - 40 x 1/4	4
19	04002087	Scr., Flat. Hd.(S. Stl.) # 5 - 40 x 5/16	2
20			
21	01200031	Scr., Hex. Soc.But. Hd. # 1/4 - 20 x 3/8	2
22*	03.5570.0.017	Material Gauge Slide - Assembly	1
23	12.0010.6.200	Magnet	4
24	70.3474.3.093	Metal Plate - Right	1
25	70.3474.3.094	Metal Plate - Left	1
*		EXTRA PARTS	
**		PICK STITCH	

Revised 12/2011

e-mail: service@amfreece.cz; parts@amfreece.cz; website: www.amfreece.com

Phone: +420 582 309 246; Fax: +420 582 360 606

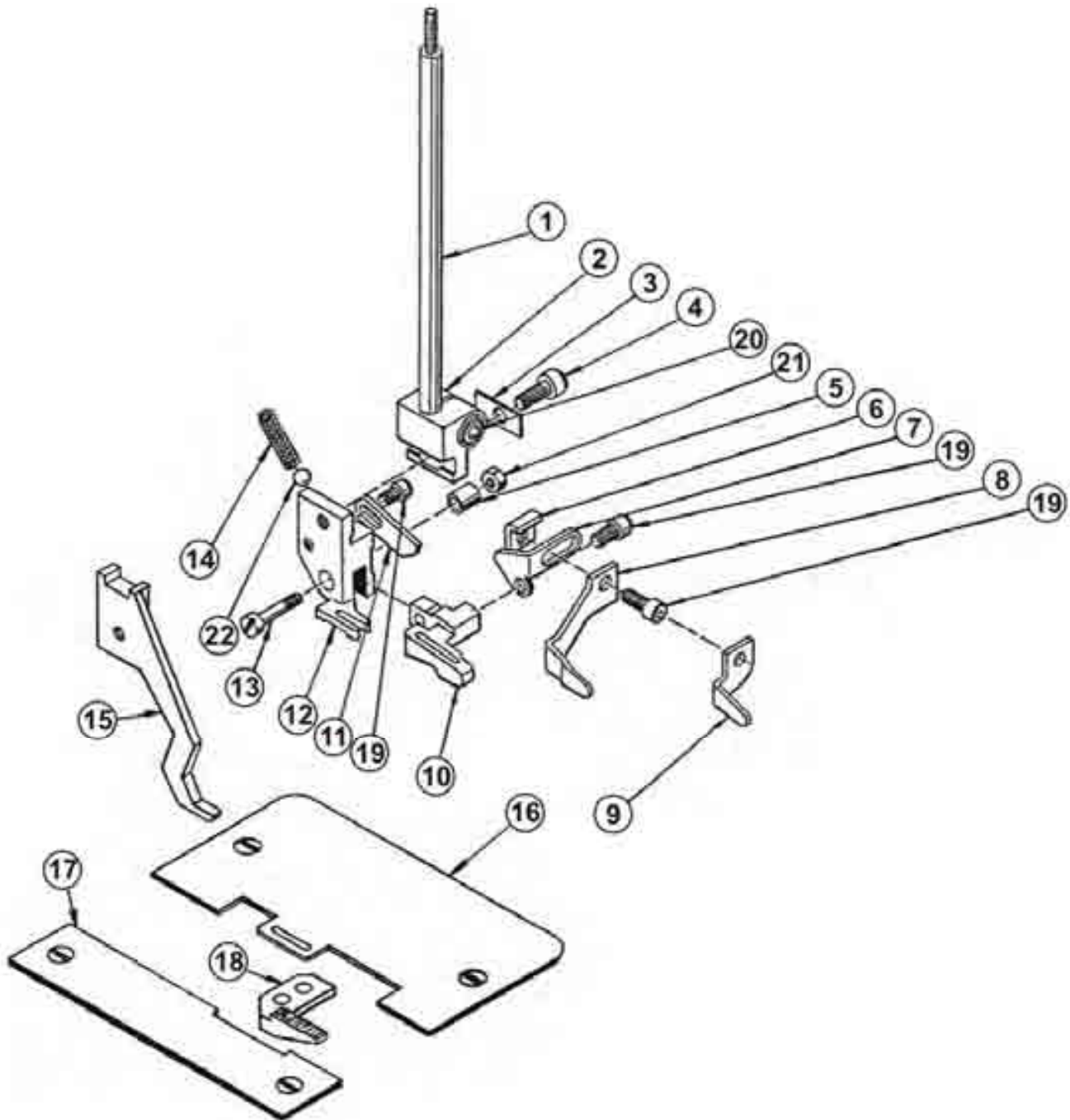
PRESSER FOOT & SWIVEL TOE ASSEMBLY - PICK STITCH

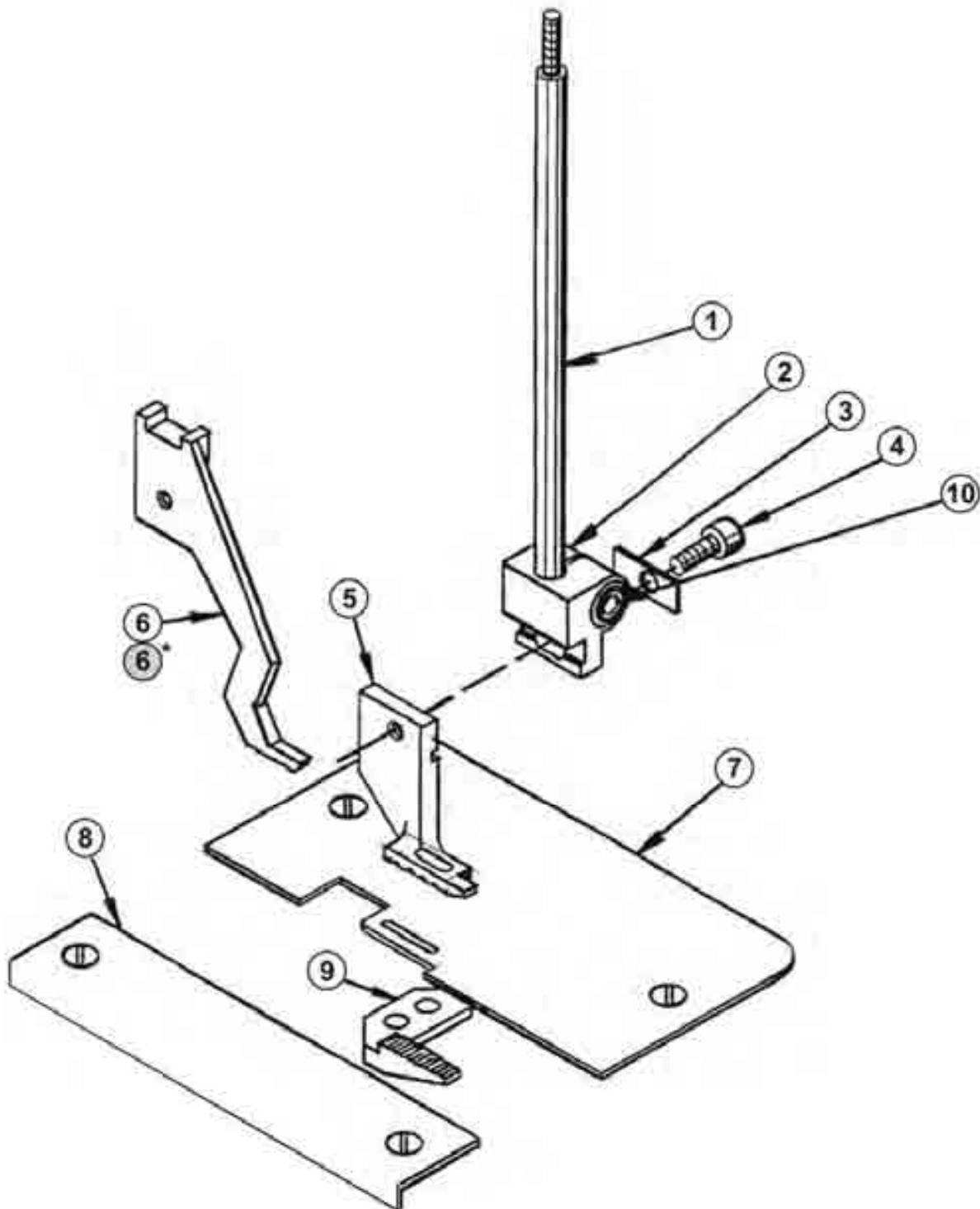
PRESSER FOOT

ELECTRICAL - I

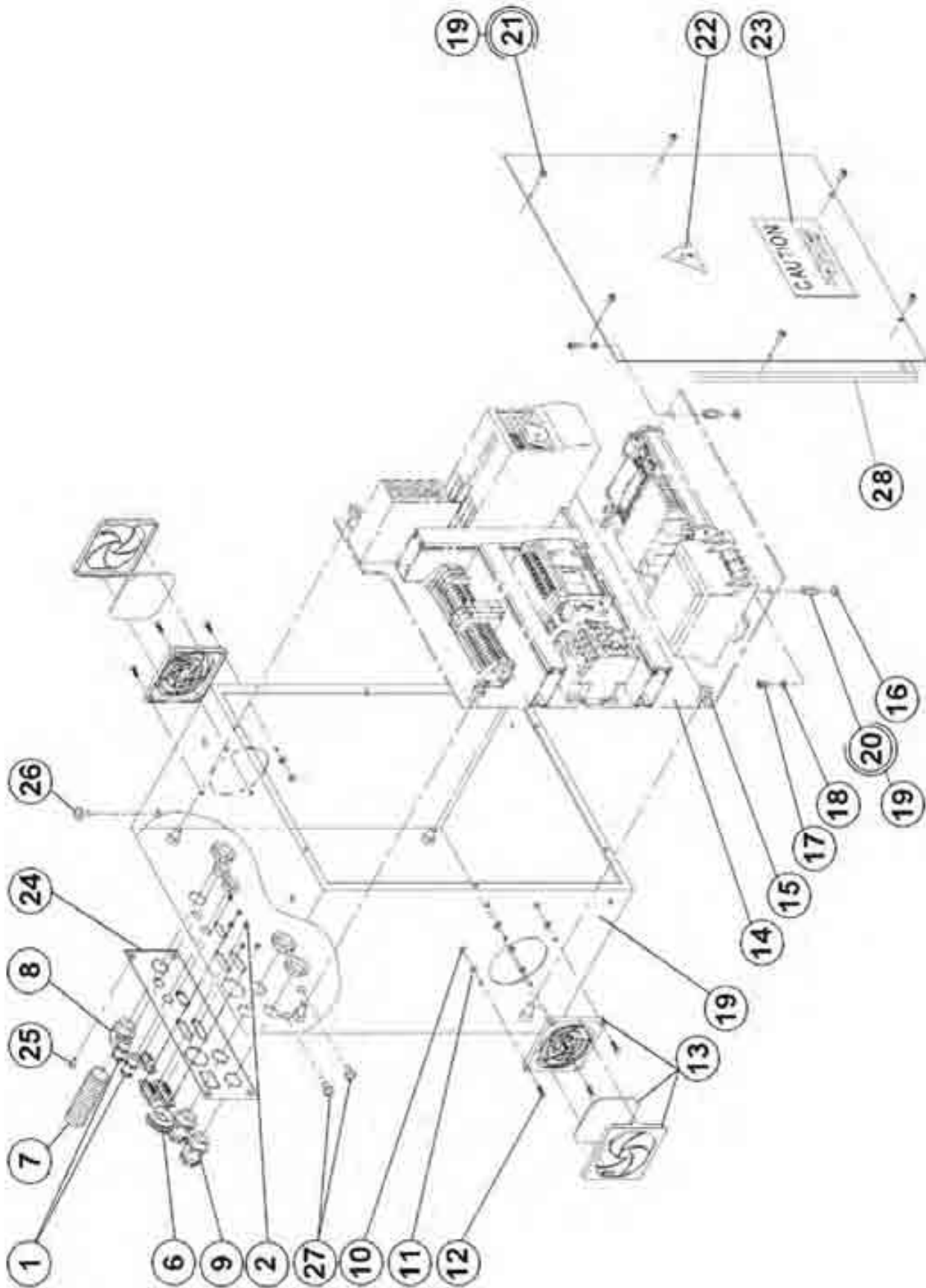

Revised 12/2011

e-mail: service@amfreece.cz; parts@amfreece.cz; website: www.amfreece.com

Phone: +420 582 309 286; Fax: +420 582 360 606

ELECTRICAL - II

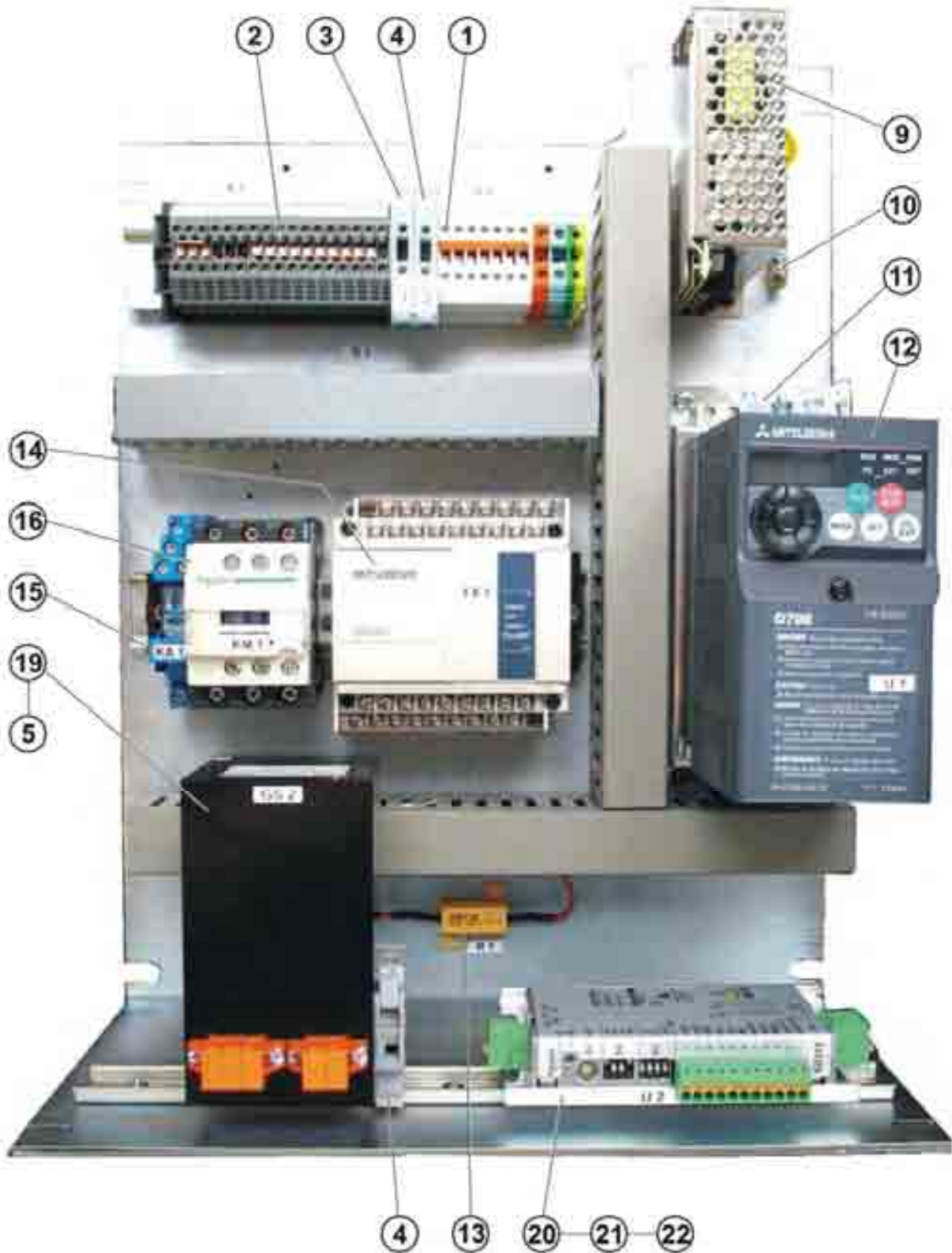

ELECTRICAL - III

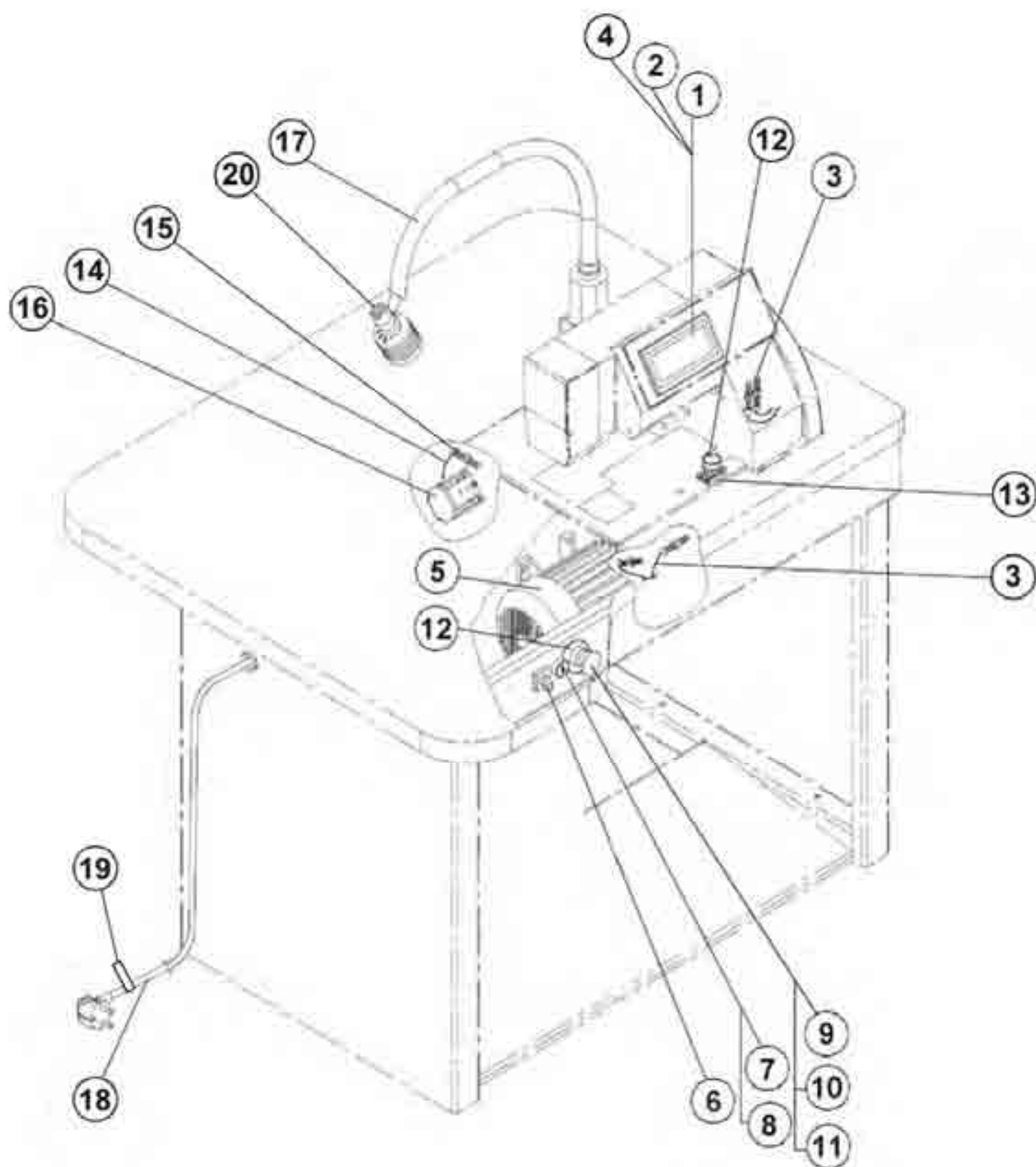

Revised 12/2011

e-mail: service@amfreece.cz; parts@amfreece.cz; website: www.amfreece.com

Phone: +420 582 309 286; Fax: +420 582 360 606

ACCESSORIES

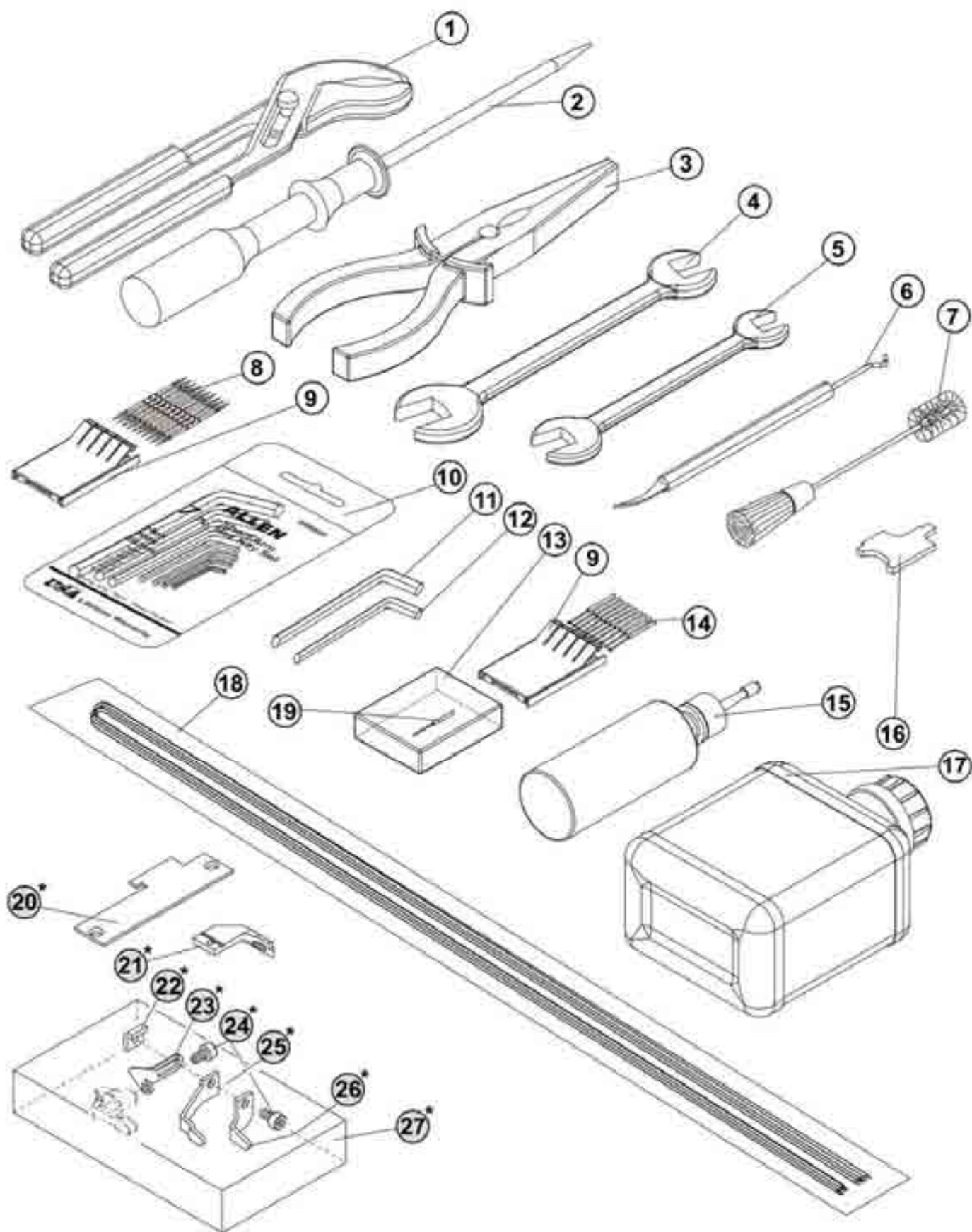

Revised 12/2011

e-mail: service@amfreece.cz; parts@amfreece.cz; website: www.amfreece.com

Phone: +420 582 309 286; Fax: +420 582 360 606

ACCESSORIES

DET	PART NUMBER	DESCRIPTION	QTY
01	26913004	Pliers	1
02	26913020	Screwdriver	1
03	12.0008.6.119	Pliers	1
04	12.0008.6.118	Wrench 7/16"x 1/2"	1
05	03.0018.0.000	Wrench 3/8" x 5/16"	1
06	49910018	Cleaner	1
07	12.0008.6.975	Perk Brush	1
08	00103238	Needle	11
09	12.0008.6.968	Box Needle Short	2
10	22979050	Wrench Set	1
11	22979048	Wrench, Short Arm	1
12	22979047	Allen Wrench 7/64"	1
13	—	Box	1
14	37213001	Needle Threader	10
15	05.1322.0.000	Oil Can ● ● ●	1
16	37771023	Gage, Needle Bar	1
17	05.0090.1.000	OIL-8 OZ CAN-68 ● ● ●	1
18	12.0008.6.xxx	Thread Black	1
19	49910019	Barbed Broach	1
20*	70.3273.2.023	Throat Plate 2 - Left	1
21*	31100035	Presser Fool	1
22*	34264012	Material Guide Nut	1
23*	35414016	Material Guide Bracket	1
24*	01000059	Screw #6-40X1/4	2
25*	34658001	Material Guide	1
26*	34458002	Material Guide	1
27*	—	Box	1

* Modification Bender Plate

Revised 12/2011

e-mail: service@amfreece.cz; parts@amfreece.cz; website: www.amfreece.com

Phone: +420 582 309 246; Fax: +420 582 360 606

THREAD TRIM

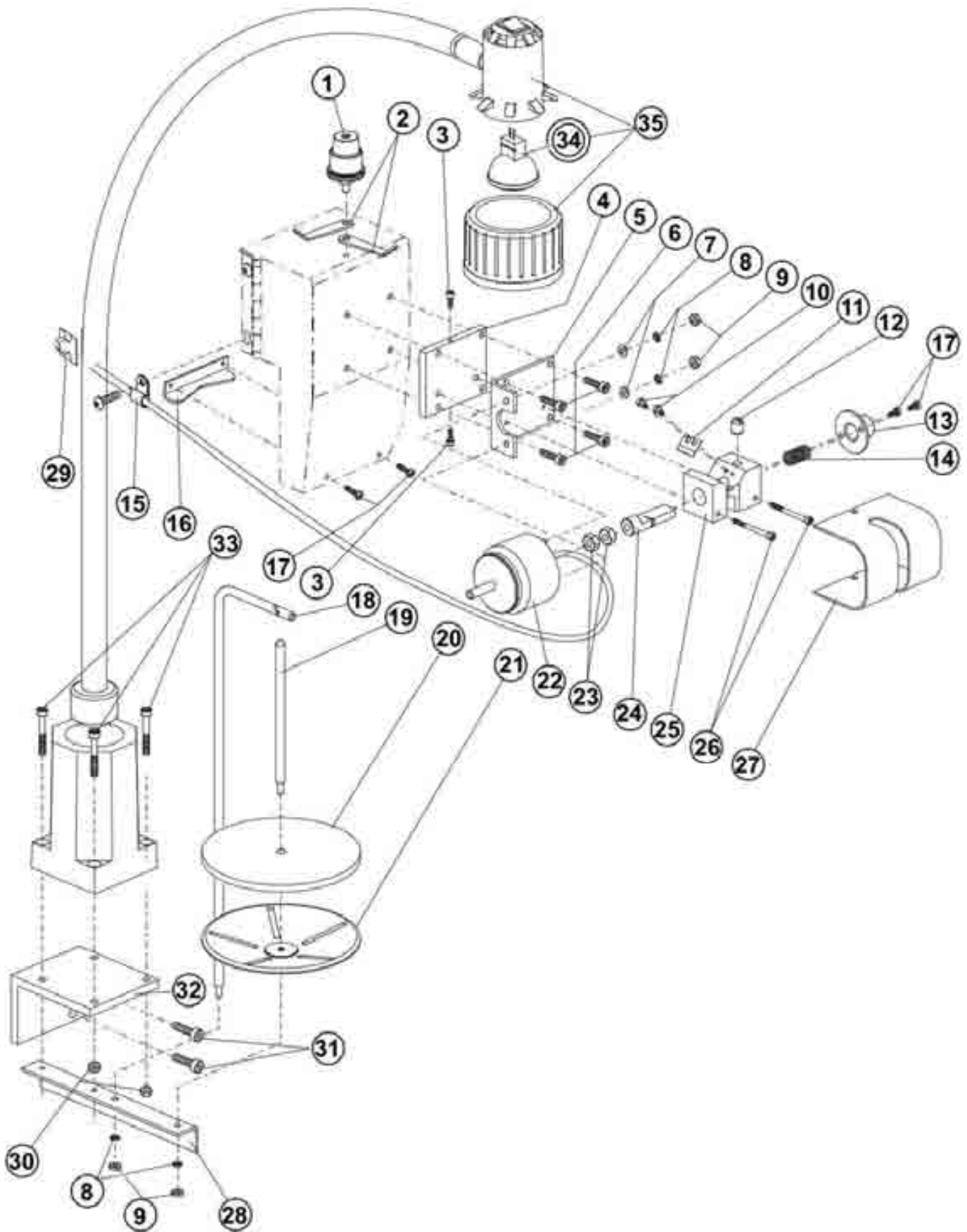

THREAD TRIM

DET	PART NUMBER	DESCRIPTION	QTY
01	24.0119.0.050	Large Tension Assembly	1
02	70.3288.2.101	Thread Guide	2
03	08.6000.3.008	Screw M3x8	2
04	70.3288.2.401	Plate	1
05	70.3288.3.601	Solenoid Holder	1
06	08.6000.4.015	Screw M4x15	4
07	08.6852.4.000	Washer 4,3	2
08	08.6802.4.000	Spring Washer 4,1	4
09	08.6702.4.000	Nut M4	4
10	08.6012.3.006	Screw	2
11	39.0087.0.000	Blade	1
12	19.0011.1.400	Screw M8x1-10	1
13	70.3284.4.101	Flange	1
14	12.3010.0.013	Spring	1
15	12.0008.4.280	Plasting Cable Fitting	1
16	70.3288.2.102	Thread Guide	1
17	08.6200.3.008	Screw M3x8	4
18	70.3288.2.103	Thread Guide	1
19	17.0031.3.277	Pin	1
20	17.0095.3.042	Washer Pad	1
21	17.0083.9.031	Plate	1
22	70.4165.1.129	Solenoid DC	1
23	08.6710.6.000	Nut M6	2
24	70.3283.2.601	Cutting Bar	1
25	70.3286.4.501	Block	1
26	08.6000.3.025	Screw M3x25	2
27	70.3288.2.104	Cover	1
28	70.3288.3.602	Holder	1
29	12.0008.4.862	Clips - Metal	3
30	08.6702.4.000	Nut M4	2
31	01200028	Screw 1/4 - 20 x 3/4	2
32	31852010	Alex Light Holder	1
33	08.6000.4.025	Screw M4x25	4
34	12.0008.4.403	Halogen Lamp Kit	1
35	12.0008.4.679	Bulb 12V/12W	(1)

Revised 07/2012

 e-mail: service@amfreece.cz; parts@amfreece.cz; website: www.amfreece.com

Phone: +420 582 309 246; Fax: +420 582 360 606

FOOT PEDAL

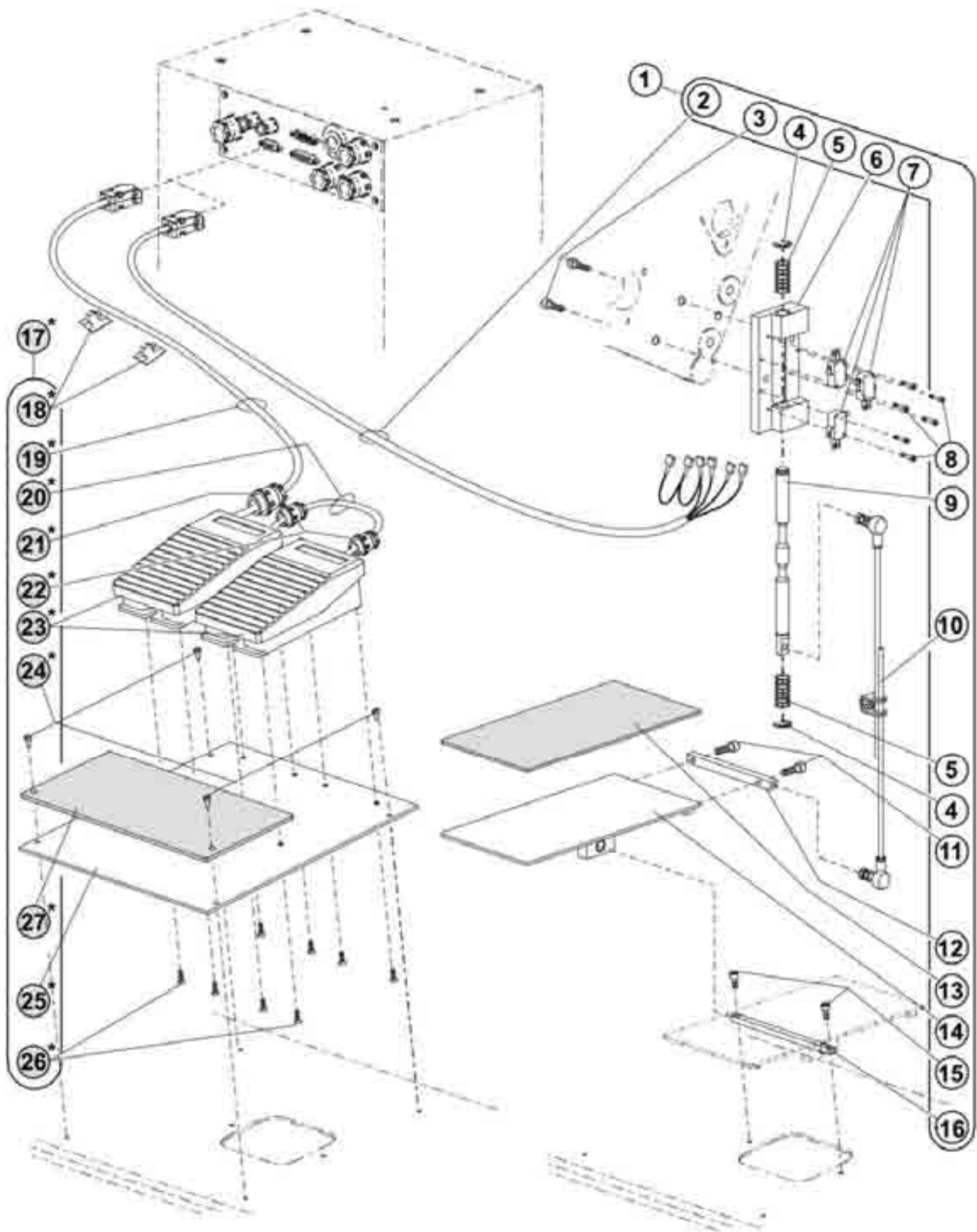

Revised 12/2011

e-mail: service@amfreece.cz; parts@amfreece.cz; website: www.amfreece.com

Phone: +420 582 309 286; Fax: +420 582 360 606

CONDENSED STITCH KIT

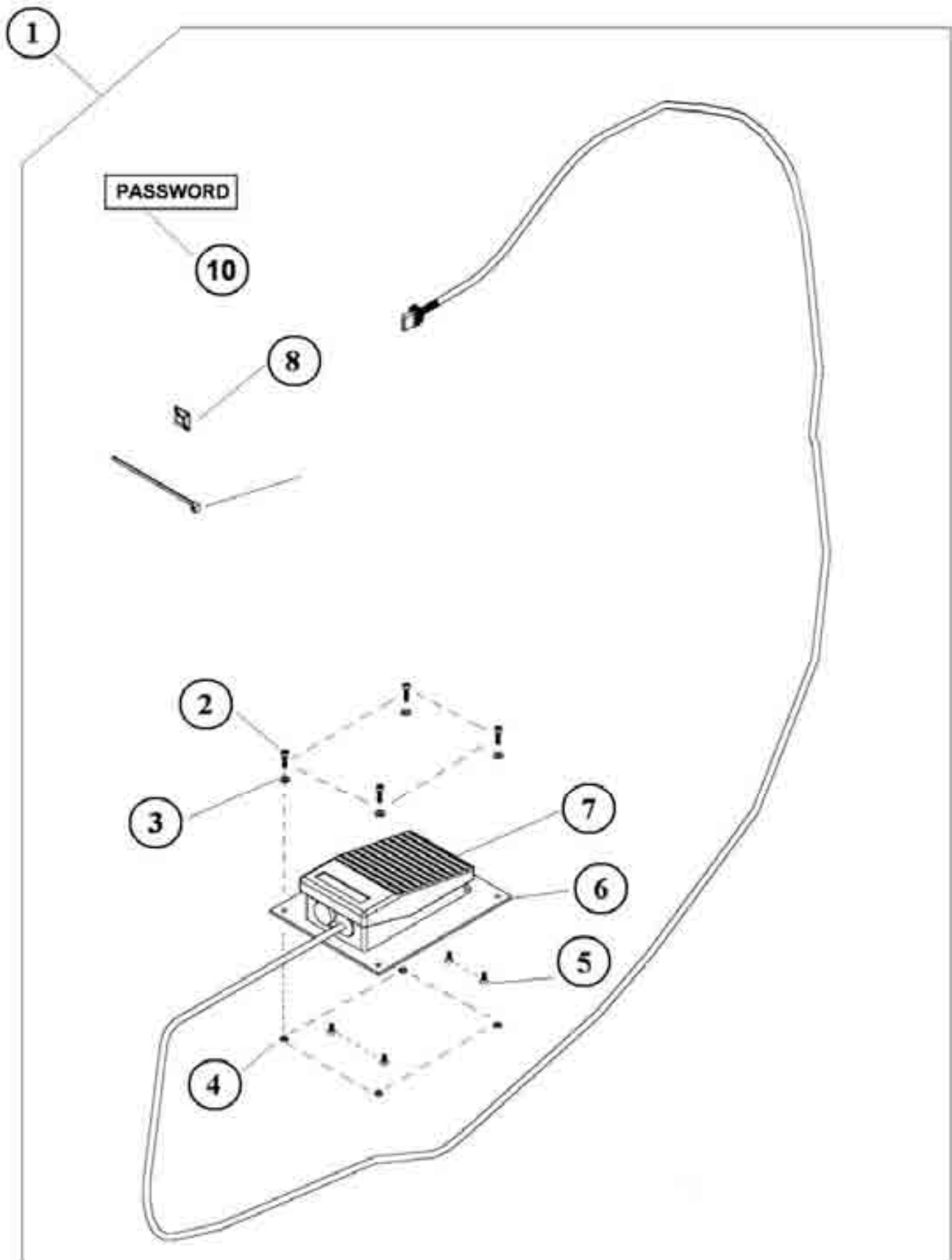

ELECTRICAL DIAGRAM

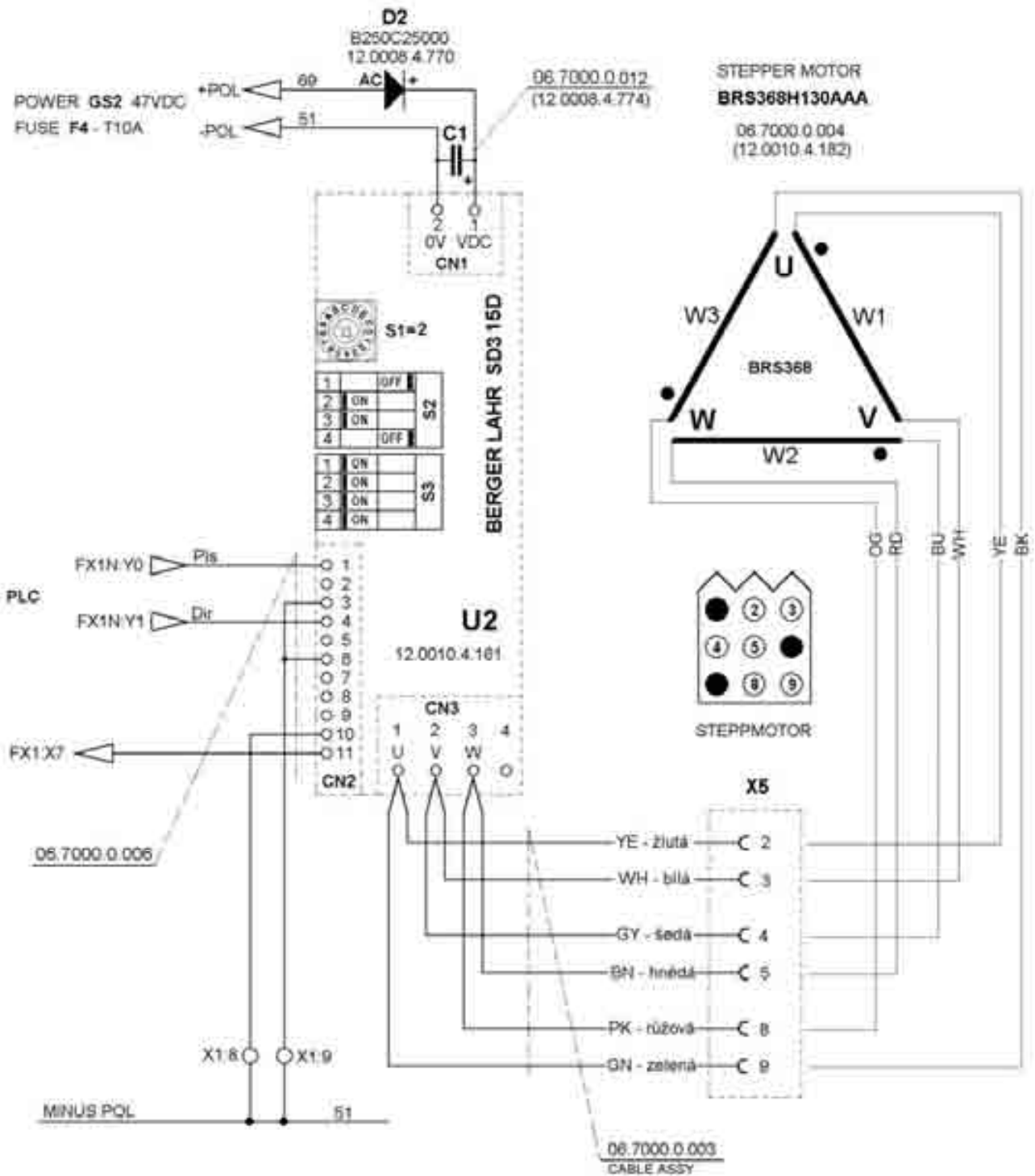

DECO M - driver U2 BACK TACK
FROM SERIAL No.: H704664 27.10.2010

MATERIAL GAUGE

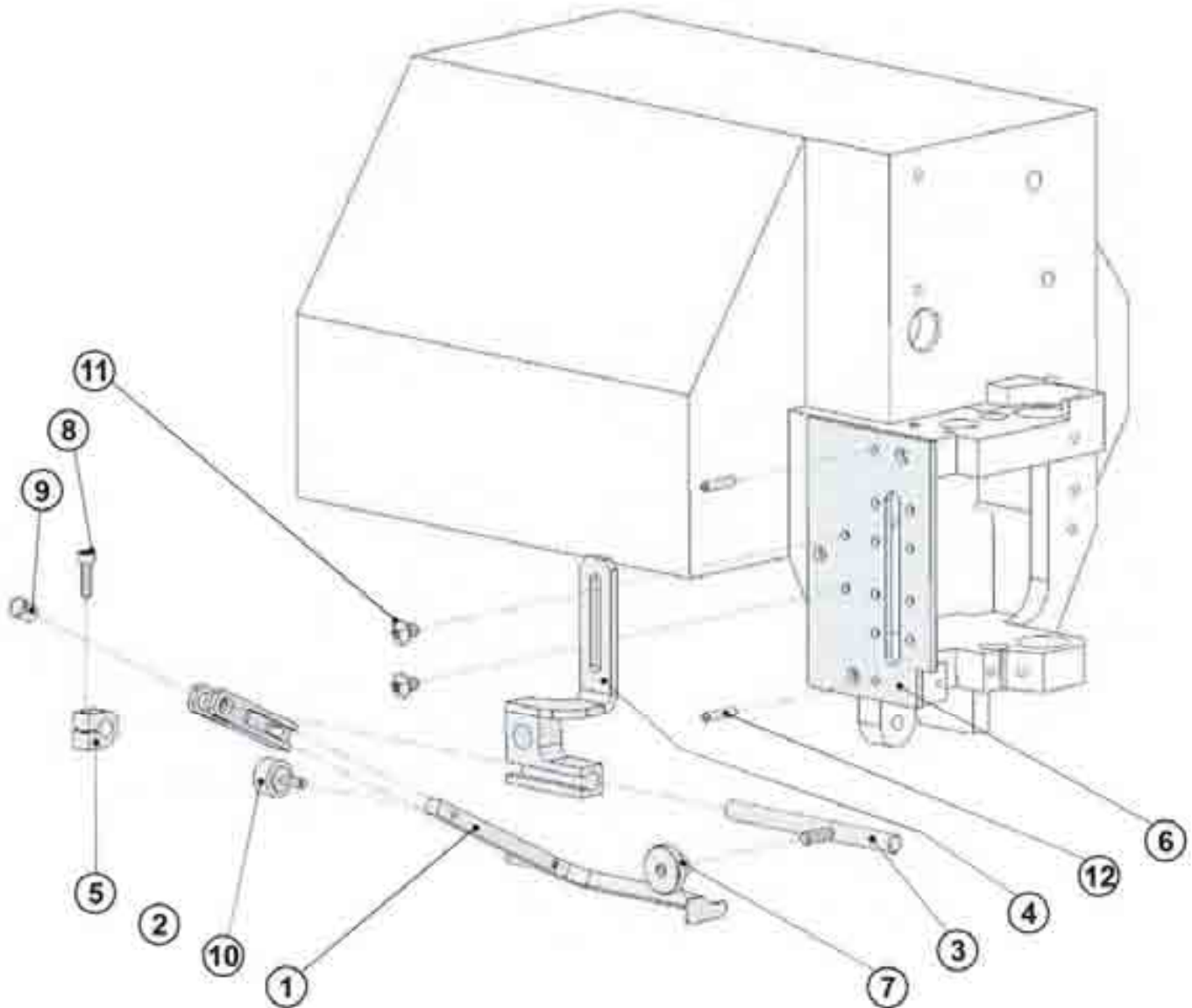

INDEX

PART NUMBER	PAGE	DET	QTY	PART NUMBER	PAGE	DET	QTY	PART NUMBER	PAGE	DET	QTY
8200025	3-65	12	2	31133018	3-13	13	1	31721038	3-13	18	1
				31151001	3-9	27	1	31721040	3-13	15	1
22911037	3-23	19	2	31151001	3-17	14	1	31721053	3-19	24	1
22911038	3-3	34	1	31215006	3-25	26	1	31721054	3-19	26	1
22912058	3-23	23	2	31215012	3-27	20	1	31723007	3-9	9	1
22912066	3-21	76	1	31225015	3-59	16	(1)	31723007	3-17	5	1
22914003	3-21	68	3	31264001	3-9	25	1	31734013	3-23	1	1
22965006	3-9	37	2	31264001	3-17	12	3	31751004	3-23	7	1
22965006	3-17	45	2	31288023	3-25	25	3	31766009	3-7	2	1
22967003	3-21	67	1	31412001	3-9	32	1	31773015	3-9	15	1
22972010	3-3	29	1	31412001	3-17	24	1	31773015	3-17	2	1
23132056	3-25	91	(2)	31413029	3-25	51	2	31781006	3-19	27	1
23132123	3-15	54	2	31413030	3-19	19	1	31838013	3-19	40	2
23132142	3-25	72	2	31413031	3-25	7	1	31838014	3-21	83	2
23132178	3-15	56	1	31423006	3-15	83	2	31838030	3-7	7	3
23132199	3-15	57	1	31423032	3-21	84	1	31845002	3-19	4	1
23132297	3-15	71	1	31423068	3-25	21	1	31852010	3-5	90	1
23161063	3-7	34	1	31428015	3-27	10	1	31852010	3-57	32	1
23161073	3-21	66	1	31464002	3-19	2	1	31873013	3-13	36	1
23161095	3-21	77	(2)	31521001	3-13	29	1	31876011	3-13	39	1
23161140	3-7	24	2	31523037	3-7	3	1	31996006	3-9	18	1
23231030	3-17	33	1	31566008	3-9	7	1	32111012	3-13	5	1
23231040	3-27	37	1	31566008	3-17	18	1	32115005	3-59	13	(1)
23231040	3-31	37	1	31571002	3-13	22	1	32115013	3-13	19	1
23231210	3-21	54	1	31572004	3-19	32	1	32121004	3-25	50	2
23231217	3-21	52	2	31593007	3-9	33	1	32216086	3-3	11	1
23231226	3-27	38	2	31593007	3-17	23	1	32217002	3-13	23	1
23231226	3-31	38	2	31611010	3-25	10	1	32221007	3-13	44	4
23522009	3-5	60	1	31611064	3-27	27	1	32223045	3-17	11	1
23914009	3-21	60	1	31611064	3-31	27	1	32241004	3-19	39	1
24116020	3-9	38	1	31612045	3-27	23	3	32434001	3-25	2	1
24116150	3-7	25	1	31612051	3-19	20	1	32533076	3-19	1	2
24117012	3-23	21	1	31641010	3-25	29	1	32643073	3-27	16	1
24117014	3-15	60	1	31641015	3-25	13	1	32652015	3-7	6	1
24323130	3-5	63	1	31641017	3-37	36	1	32691001	3-27	5	2
24383030	3-5	73	1	31641019	3-25	14	1	32729001	3-13	41	1
24423030	3-5	64	1	31642007	3-13	34	1	32731026	3-13	10	1
24473075	3-5	72	1	31652001	3-7	13	1	32732001	3-13	42	1
25379218	3-25	63	1	31674025	3-9	1	1	33182005	3-9	23	1
26913025	3-15	66	1	31674025	3-17	26	1	33182005	3-17	21	1
27571120	3-3	37	1	31695011	3-9	2	1	33215066	3-9	17	1
				31695011	3-17	27	1	33242002	3-13	24	1
31000008				31697003	3-9	29	1	33244009	3-25	9	1
31000008	3-23	4	1	31697003	3-17	10	1	33252029	3-27	15	1
31000008	3-27	11	1					33256011	3-13	38	1
31000030	3-5	101	1	31715005				33257001	3-25	1	1
31000031	3-5	102	1	31715005	3-19	3	1	33258075	3-27	17	1
31111009	3-9	30	1	31718025	3-19	18	1	33334012	3-25	31	1
31111009	3-17	17	1	31718027	3-13	32	1				
31112002	3-25	47	2	31721022	3-27	18	1				

INDEX

PART NUMBER	PAGE	DET	QTY	PART NUMBER	PAGE	DET	QTY	PART NUMBER	PAGE	DET	QTY
33422001				36221009				36651001	3-13	2	1
33422001	3-13	37	1	36221009	3-27	13	1	36651002	3-13	7	1
33441002	3-17	15	1	36221009	3-31	13	1	36651008	3-19	6	1
33441003	3-9	28	1	36223009	3-23	8	1	36653010	3-19	31	1
34111085	3-19	14	2	36224009	3-7	44	1	36661001	3-25	4	1
34125140	3-5	61	1	36224010	3-7	4	2	36672047	3-13	26	1
34221010	3-13	27	1	36226017	3-7	15	1	36673028	3-25	26	1
34264012	3-55	22*	1	36227019	3-13	3	1	36677016	3-27	19	1
34268125	3-5	53	1	36228009	3-7	16	1	36691014	3-9	12	1
34372004	3-19	16	1	36228020	3-7	5	1	36691014	3-17	4	1
34372042	3-27	8	1	36271006	3-19	7	1	36691021	3-27	21	1
34416044	3-3	45	1	36271013	3-13	4	1	36713007	3-7	11	1
34585001	3-19	34	1	36341050	3-19	36	1	36771021	3-9	6	1
34647001	3-19	13	1	36513046	3-23	5	1	36771021	3-17	19	1
34732023	3-13	43	1	36514046	3-23	9	1	36773007	3-15	62	1
34732023	3-65	6	1	36515013	3-23	10	1	36773008	3-15	61	1
35131002	3-9	24	1	36515032	3-7	17	1	37112030	3-19	46	(2)
35131002	3-17	9	1	36516014	3-23	6	1	37211018	3-19	37	1
35315013	3-3	4	1	36516040	3-7	10	1	37211131	3-27	26	1
35351180	3-3	13**	1**	36518027	3-27	3	1	37211131	3-31	26	1
35371003	3-3	3	1	36518029	3-19	35	1	37213001	3-9	19	1
35371004	3-19	47	1	36518030	3-9	21	1	37711017	3-3	5	1
35472011	3-3	20	1	36518030	3-17	7	1				
35511021	3-9	8	1	36518077	3-13	6	1	41214006	3-3	18	2
35511021	3-17	16	1	36523021	3-17	25	1	41321019	3-3	2	1
35511045	3-27	1	1	36523022	3-9	26	1	41441060	3-3	12	1
35511048	3-9	08**	1**	36523022	3-17	13	1	41831082	3-19	28	1
35511048	3-17	16**	1**	36531010	3-9	5	1	42531081	3-9	10	1
35511081	3-9	08*	1*	36531010	3-17	20	1	42531081	3-17	1	1
35511081	3-17	16*	1*	36532021	3-9	3	1				
35521048	3-9	13	1	36532021	3-17	28	1	00.2751.3.602	3-49	23	1
35521048	3-17	3	1	36532022	3-9	4	1	00103228	3-17	08*	1
35521049	3-17	5	1	36532022	3-17	29	1	00103228	3-9	20*	1*
35521055	3-13	11	1	36532025	3-25	24	1	00103238	3-9	20	1
35523026	3-5	65	1	36541005	3-13	40	2	00103238	3-17	8	1
35526005	3-27	4	1	36542017	3-19	15	1	00103238	3-55	8	11
35541070	3-19	46	1	36542018	3-27	2	1	00103249	3-17	08**	1
35542007	3-27	9	1	36543018	3-13	8	1	00103249	3-9	20**	1**
35551002	3-25	3	1	36543019	3-19	38	1				
35561001	3-19	9	1	36543020	3-13	30	1	01.2548.0.000	3-23	18	1
35571021	3-13	35	1	36546023	3-9	34	1	01.7305.0.900	3-25	59	(2)
35633040	3-19	22	1					01.7435.1.000	3-35	68	2
35633041	3-19	30	1	36613036							
35771051	3-13	45	1	36613036	3-13	31	1	01000002	3-45	20	1
35778014	3-19	17	1	36613038	3-25	22	1	01000002	3-47	10	1
35812048	3-19	29	1	36617003	3-59	14	(1)	01000002	3-21	93	2
35812049	3-7	1	1	36619044	3-13	20	1	01000002	3-25	65	2
35815007	3-27	24	1	36621001	3-13	25	2	01000004	3-15	74	2
35815007	3-31	24	1	36631031	3-9	16	1	01000004	3-45	19	3
				36647001	3-25	27	1	01000005	3-27	39	1

INDEX

PART NUMBER	PAGE	DET	QTY	PART NUMBER	PAGE	DET	QTY	PART NUMBER	PAGE	DET	QTY
01000005	3-31	39	1	01200026	3-57	31	2	04000053	3-15	70	1
01000006	3-15	62	3	01200031	3-43	21	2	04000190	3-41	54	1
01000013	3-11	46	1	01200063	3-7	38	1	04002086	3-43	18	2
01000013	3-15	77	1	01300029	3-39	45	1	04002086	3-43	18**	4
01000013	3-17	44	1	01300037	3-39	41	1	04002087	3-43	19	2
01000013	3-35	73	2					04002109	3-43	17	4
01000017	3-35	75	1	02060018	3-3	33	12	04100011	3-21	61	1
01000018	3-35	53	1					04100052	3-5	52	2
01000019	3-59	11	(2)	03.0018.0.000	3-55	5	1	04100053	3-21	62	4
01000025	3-37	34	1	03.5570.0.011	3-59	1	1	04100054	3-25	83	1
01000026	3-35	79	1	03.5570.0.013	3-61	1	1	04100054	3-7	21	2
01000026	3-21	53	4	03.5570.0.014	3-59	17*	1*	04100054	3-15	81	2
01000027	3-27	49	1	03.5570.0.017	3-43	22*	1	04100054	3-41	51	2
01000032	3-37	29	2					04100070	3-15	50	1
01000032	3-15	79	3	03100002	3-37	21	1	04120001	3-15	75	1
01000032	3-43	14	(2)	03100006	3-9	42	1	04120001	3-29	55	2
01000037	3-41	59	1	03100008	3-29	59	1	04120001	3-31	55	2
01000037	3-25	69	2	03100008	3-31	59	1	04120002	3-27	35	1
01000039	3-9	44	3	03100012	3-15	63	1	04120002	3-31	35	1
01000039	3-17	35	5	03100012	3-21	80	1	04120004	3-29	58	1
01000047	3-27	42	1	03100012	3-25	67	1	04120004	3-31	58	1
01000047	3-31	42	1	03100012	3-35	57	1	04120005	3-21	65	2
01000047	3-3	23	2	03100012	3-23	17	2	04120006	3-15	78	1
01000047	3-25	60	2	03100013	3-21	55	1	04120012	3-29	54	1
01000056	3-35	84	4	03100013	3-33	49	2	04120012	3-31	54	1
01000058	3-27	32	1	03100017	3-15	65	1	04120070	3-43	16	2
01000058	3-31	32	1	03100038	3-29	53	1	04122093	3-15	80	8
01000058	3-15	68	1	03100038	3-31	53	1	04140040	3-3	36	6
01000059	3-35	56	1	03100051	3-35	52	3	04200003	3-7	27	4
01000059	3-55	24*	2	03100066	3-17	32	2	04200003	3-3	30	6
01000093	3-39	42	1	03100066	3-25	70	2	04200004	3-3	43	5
01000099	3-7	29	1	03100147	3-29	56	1	04200007	3-15	55	1
01000298	3-9	40	1	03100147	3-31	56	1	04200011	3-9	35	1
01000301	3-15	73	1	03100154	3-31	44	1	04200011	3-35	64	1
01000301	3-45	4	1	03100154	3-27	44	2	04200012	3-7	36	1
01000301	3-47	4	1	03101038	3-27	50	1	04200012	3-21	85	1
01002014	3-41	57	1	03102026	3-27	45	1	04200013	3-7	35	1
01002015	3-21	71	1	03102026	3-33	47	1	04200027	3-3	41	2
01002015	3-27	43	2	03102026	3-35	65	1	04200027	3-21	56	11+(1)
01002040	3-7	31	1	03130001	3-11	49	2	04200030	3-33	50	1
01002106	3-17	40	1	03130001	3-17	41	2	04200031	3-21	59	3
01200001	3-7	28	2	03140003	3-25	74	1	04200039	3-15	76	1
01200005	3-7	22	2	03140005	3-37	27	1	04200039	3-27	48	1
01200007	3-9	36	1	03140006	3-41	63	1	04200046	3-35	80	1
01200011	3-21	72	2	03200023	3-7	33	1	04200051	3-21	79	4
01200011	3-21	89	2					04200057	3-7	26	1
01200011	3-65	11	2	04.1956.1.000	3-59	10	(1)	04200267	3-7	37	1
01200019	3-21	81	1	04.9070.0.000	3-3	1	1	04202013	3-21	63	2
01200024	3-3	39	2								
01200024	3-3	21	3	04000020	3-21	74	2	05.0090.1.000	3-55	17	1

INDEX

PART NUMBER	PAGE	DET	QTY	PART NUMBER	PAGE	DET	QTY	PART NUMBER	PAGE	DET	QTY
05.1322.0.000	3-55	15	1	07012003	3-3	32	6	08.6400.4.008	3-35	86	3
				07012004	3-29	52	1	08.6700.4.000	3-3	9	2
06.0120.0.000	3-59	7	(1)	07012005	3-41	56	1	08.6700.4.000	3-49	10	8
06.7000.0.003	3-53	14	1	07012005	3-25	61	2	08.6702.4.000	3-57	30	2
06.7000.0.004	3-53	16	1	07012010	3-21	75	3+(1)	08.6702.4.000	3-57	9	4
06.7000.0.005	3-51	13	1	07016002	3-29	57	2	08.6702.4.000	3-61	4	4
06.7000.0.010	3-53	4	1	07016002	3-31	57	2	08.6702.5.000	3-49	16	2
06.7000.0.012	3-51	22	1	07100009	3-7	39	1	08.6702.8.000	3-49	15	4
				07100009	3-35	81	1	08.6710.6.000	3-57	23	2
06000002	3-21	82	1	07100009	3-3	31	4	08.6800.4.000	3-49	11	8
06000002	3-35	63	1	07100011	3-35	54	2	08.6802.4.000	3-31	63	0
06000002	3-25	58	2	07102006	3-37	35	1	08.6802.4.000	3-29	63	1
06000002	3-15	72	4	07102007	3-27	41	1	08.6802.4.000	3-57	6	4
06000003	3-31	33	1	07102007	3-31	41	1	08.6850.4.000	3-3	10	6
06000004	3-21	64	3	07102007	3-21	94	2	08.6852.4.000	3-31	64	0
06000005	3-35	65	1	07102007	3-25	62	2	08.6852.4.000	3-29	64	1
06000014	3-5	59	2	07106001	3-39	49	1	08.6852.4.000	3-57	7	2
06000014	3-35	74	2	07106002	3-9	36	1	08.6852.4.000	3-61	3	4
06000020	3-45	21	1					08.6852.5.000	3-49	18	2
06002001	3-9	43	1	08.6000.0.025	3-3	28	4	08.6852.6.000	3-33	16	1
06002001	3-17	46	1	08.6000.3.008	3-57	3	2				
06020004	3-35	58	1	08.6000.3.012	3-65	8	1	08000007	3-25	80	1
06020015	3-3	22	3	08.6000.3.016	3-59	6	(6)	08000007	3-33	40	1
06020019	3-11	50	2	08.6000.3.025	3-57	26	2	08000015	3-27	31	1
06020019	3-17	43	2	08.6000.4.008	3-5	79	4	08000015	3-31	31	1
06020019	3-21	90	2	08.6000.4.010	3-31	62	0	08000015	3-37	26	1
06020019	3-21	73	4	08.6000.4.010	3-29	62	1	08000016	3-21	69	4
06020021	3-35	59	1	08.6000.4.010	3-35	94	4	08000017	3-41	58	1
06030014	3-21	58	1	08.6000.4.012	3-11	51	2	08000018	3-41	61	2
06104001	3-11	46	1	08.6000.4.015	3-57	6	4	08000019	3-3	42	4
06104001	3-17	34	1	08.6000.4.016	3-61	2	4	08000022	3-21	78	2
06124010	3-37	31	2	08.6000.4.020	3-33	48	2	08000044	3-31	40	1
06130002	3-37	28	2	08.6000.4.025	3-57	33	4	08000044	3-35	71	1
06220001	3-39	50	1	08.6000.5.012	3-59	15	(2)	08000044	3-25	56	2
				08.6000.6.018	3-59	3	(2)	08000044	3-27	40	2
07.6440.0.014	3-59	5	(2)	08.6012.3.006	3-57	10	2	08000109	3-25	57	1
07.6440.0.050	3-19	25	1	08.6012.4.010	3-59	24*	(4)*	08000110	3-25	73	1
07.6760.0.000	3-59	4	(2)	08.6032.5.010	3-49	17	2	08002028	3-17	37	1
				08.6100.4.008	3-49	25	4	08200024	3-3	40	2
07002002	3-29	51	2	08.6100.4.014	3-49	12	8	08200031	3-7	23	1
07002009	3-21	57	1	08.6100.4.014	3-59	26*	(8)*	08322001	3-37	24	1
07012001	3-31	36	1	08.6132.4.010	3-61	5	4	08504001	3-27	34	2
07012001	3-23	20	2	08.6200.3.005	3-11	58	4	08504001	3-31	34	2
07012001	3-27	36	2	08.6200.3.008	3-57	17	4				
07012001	3-35	55	2	08.6200.4.010	3-3	8	4	09020001	3-15	59	1
07012001	3-37	30	2	08.6400.4.005	3-31	61	0	09020001	3-21	51	1
07012001	3-43	15	(2)	08.6400.4.005	3-29	61	1	09020001	3-35	66	1
07012002	3-37	22	1	08.6400.4.005	3-39	4	1	09020001	3-23	15	2
07012002	3-25	68	2	08.6400.4.006	3-7	46	1				
07012003	3-35	62	1	08.6400.4.008	3-7	43	1	12.0008.3.244	3-31	30	1

INDEX

PART NUMBER	PAGE	DET	QTY	PART NUMBER	PAGE	DET	QTY	PART NUMBER	PAGE	DET	QTY
12.0008.4.050	3-51	10	1	12.0008.6.523	3-3	24A	4	23181235	3-35	76	1
12.0008.4.058	3-61	8	8	12.0008.6.958	3-55	9	2	23231030	3-9	45	(1)
12.0008.4.064	3-51	5	1	12.0008.6.975	3-55	7	1	23231040	3-37	25	1
12.0008.4.072	3-61	9	8	12.0008.6.979	3-11	53	1	23231045	3-33	23	1
12.0008.4.204	3-59	23*	(2)*	12.0008.8.xxx	3-55	18	1	23231045	3-39	46	1
12.0008.4.207	3-49	1	2	12.0010.4.025	3-53	3	4				
12.0008.4.215	3-49	28	2	12.0010.4.093	3-53	15	1	24.0119.0.050	3-57	1	1
12.0008.4.216	3-49	27	2	12.0010.4.112	3-53	2	1				
12.0008.4.231	3-49	9	2	12.0010.4.113	3-53	9	1	24117010	3-41	55	1
12.0008.4.231	3-59	22*	(2)*	12.0010.4.161	3-51	20	1	24117012	3-35	62	1
12.0008.4.240	3-59	21*	(1)*	12.0010.4.195	3-51	19	1	24117216	3-37	20	1
12.0008.4.280	3-57	15	1	12.0010.6.200	3-43	23	4	24971021	3-41	62	1
12.0008.4.366	3-49	6	1	12.1016.0.001	3-5	75	2	24971056	3-39	48	1
12.0008.4.378	3-49	22	1	12.3010.0.013	3-57	14	1				
12.0008.4.403	3-53	17	1	12.3010.0.014	3-11	55	1	25379273	3-37	33	1
12.0008.4.403	3-57	34	1	12.3011.0.006	3-39	39	1				
12.0008.4.472	3-49	13	2	12.3013.0.005	3-65	9	1	26913004	3-55	1	1
12.0008.4.488	3-51	16	1	12.5050.2.029	3-35	92	1	26913020	3-55	2	1
12.0008.4.590	3-53	9	1	12.8000.0.112	3-53	19	1				
12.0008.4.591	3-53	12	1	12.8000.0.144	3-61	10	1	31000006			
12.0008.4.592	3-53	13	1	12.8000.1.010	3-5	74	1	31000006	3-33	38	1
12.0008.4.596	3-21	95	2					31000009	3-31	11	1
12.0008.4.664	3-51	4	2	17.0004.7.253	3-21	86	(1)	31000018	3-33	44	1
12.0008.4.665	3-51	3	1	17.0011.2.013	3-7	42	2	31000032	3-37	6	1
12.0008.4.679	3-53	20	1	17.0011.2.013	3-7	47	(2)	31000033	3-37	7	1
12.0008.4.679	3-57	35	(1)	17.0017.2.041	3-65	7	1	31100035	3-55	21*	1
12.0008.4.709	3-51	9	1	17.0031.3.277	3-57	19	1	31211015	3-39	12	1
12.0008.4.710	3-49	2	6	17.0083.9.031	3-57	21	1	31215002	3-33	15	1
12.0008.4.720	3-51	15	1	17.0095.3.042	3-57	20	1	31215079	3-33	41	1
12.0008.4.721	3-51	15	1					31217001	3-33	7	1
12.0008.4.722	3-51	15	1	19.0011.1.400	3-57	12	1	31268001	3-39	6	1
12.0008.4.723	3-51	15	1	19.0044.1.624	3-7	41	1	31283001	3-37	9	1
12.0008.4.751	3-51	11	1	19.0044.1.625	3-7	48	1	31288023	3-37	13	1
12.0008.4.757	3-53	5	1					31288023	3-33	17	2
12.0008.4.770	3-51	21	1	22912090	3-35	67	2	31413001	3-39	27	1
12.0008.4.783	3-49	7	1	22965005	3-45	22	1	31413002	3-39	23	1
12.0008.4.795	3-49	8	1	22966116	3-43	13	(1)	31413003	3-45	5	1
12.0008.4.835	3-53	6	1	22979047	3-55	12	1	31421005	3-33	24	1
12.0008.4.836	3-53	7	1	22979048	3-55	11	1	31426015	3-31	10	1
12.0008.4.837	3-53	8	1	22979050	3-55	10	1	31511015	3-33	22	1
12.0008.4.839	3-53	10	1					31593001	3-39	29	1
12.0008.4.842	3-53	11	1	23132030	3-9	41	(2)	31612052	3-33	19	1
12.0008.4.862	3-59	18*	(2)*	23132115	3-37	32	(1)	31612054	3-35	60	1
12.0008.4.862	3-57	29	3	23132122	3-35	61	3	31613007	3-37	3	1
12.0008.4.885	3-53	18	1	23132155	3-35	78	(1)	31613035	3-39	31	1
12.0008.6.118	3-55	4	1	23132165	3-41	60	(1)	31644003	3-39	17	1
12.0008.6.119	3-55	3	1	23132178	3-39	43	1	31644004	3-33	37	1
12.0008.6.517	3-5	69	4	23161008	3-35	83	(2)	31685012	3-45	13	1
12.0008.6.520	3-3	25	4	23161048	3-35	70	(1)	31721038	3-37	12	1
12.0008.6.521	3-3	24B	4	23161073	3-35	51	(6)	31721039	3-11	47	1

INDEX

PART NUMBER	PAGE	DET	QTY	PART NUMBER	PAGE	DET	QTY	PART NUMBER	PAGE	DET	QTY
31721038	3-33	25	1	35526005	3-31	4	1	70.3165.2.002	3-5	70	1
31721041	3-41	64	1	35542007	3-31	9	1	70.3165.2.002	3-7	40	1
31722031	3-39	2	1					70.3165.2.003	3-7	45	1
31728003	3-33	31	1	36226011				70.3172.1.024	3-13	14	1
31741013	3-39	40	1	36226011	3-33	1	1	70.3285.2.016	3-5	57	1
31772035	3-45	1	1	36341035	3-39	21	1	70.3285.2.017	3-11	56	1
31772035	3-47	1	1	36344057	3-33	28	1	70.3271.1.020	3-3	6	2
31773013	3-33	6	2	36515020	3-33	29	1	70.3271.1.025	3-11	57	1
31815017	3-39	26	1	36518027	3-31	3	1	70.3273.2.023	3-55	20	1
31839020	3-37	18	1	36531018	3-45	14	1	70.3276.4.008	3-47	8	1
31852016	3-33	13	1	36533016	3-37	16	1	70.3276.4.009	3-47	7	1
31873011	3-37	17	1	36542018	3-31	2	1	70.3282.7.100	3-25	43	0
31881004	3-33	4	1	36543022	3-37	10	1	70.3283.2.601	3-57	24	1
31955003	3-39	16	1	36546022	3-39	37	1	70.3284.4.101	3-57	13	1
				36546024	3-33	39	1	70.3286.4.501	3-57	25	1
32215003				36613034	3-33	10	1	70.3288.2.101	3-57	2	2
32215003	3-45	3	1	36615007	3-45	12	1	70.3288.2.102	3-57	16	1
32215003	3-47	3	1	36667012	3-33	26	1	70.3288.2.103	3-57	18	1
32225017	3-33	21	1	36674012	3-37	14	1	70.3288.2.104	3-57	27	1
32233001	3-43	8	1	36678019	3-33	30	1	70.3288.2.401	3-57	4	1
32428002	3-33	14	1	36691022	3-33	20	1	70.3288.3.601	3-57	5	1
32542111	3-39	18	1	36691024	3-39	5	1	70.3288.3.602	3-57	28	1
32631001	3-45	11	1	36741109	3-43	1	(1)	70.3288.3.604	3-21	92	1
32891001	3-31	5	2	36771079	3-33	34	1	70.3288.3.605	3-21	91	1
32732021	3-45	17	1	37211045	3-39	30	1	70.3324.2.003	3-13	24	1
32739004	3-33	11	1	37211133	3-43	9	1	70.3325.1.109	3-3	16	1
32764006	3-45	16	1	37213001	3-55	14	10	70.3325.1.108	3-3	7	1
32769003	3-37	8	1	37231026	3-39	20	1	70.3325.8.077	3-43	3	1
33251105	3-39	10	1	37771022	3-43	2	(1)	70.3325.8.091	3-65	1	1
33258076	3-43	03**	1	37771023	3-55	16	1	70.3325.8.092	3-65	2	1
34264012	3-45	6	1					70.3325.8.093	3-65	5	1
34372042	3-31	6	1	39.0013.3.000	3-65	10	1	70.3325.8.094	3-65	3	1
34378066	3-39	9	1	39.0087.0.000	3-57	11	1	70.3325.8.095	3-65	4	1
34458002	3-45	9	1					70.3441.8.045	3-21	87	1
34458002	3-55	26*	1	42241009	3-39	38	1	70.3441.6.046	3-21	88	1
34658001	3-45	8	1	49910018	3-55	6	1	70.3462.7.067	3-33	33	1
34658001	3-55	25*	1	49910019	3-55	19	1	70.3474.3.093	3-43	24	1
34758001	3-37	5	1					70.3474.3.094	3-43	25	1
35111007	3-37	1	1	70.2691.1.188	3-13	49	1	70.3532.8.073	3-59	25*	(1)*
35225010	3-33	35	1	70.3100.0.020	3-33	45	1	70.3532.8.075	3-59	6	(1)
35411121	3-43	07**	1	70.3100.0.040	3-35	93	1	70.3532.8.076	3-59	9	(1)
35414016	3-45	7	1	70.3100.0.042	3-5	66	1	70.3532.8.077	3-59	12	(1)
35414016	3-55	23*	1	70.3100.0.043	3-33	46	1	70.3532.8.078	3-61	6	1
35511040	3-39	34	1	70.3110.0.038	3-47	5	1	70.3535.1.181	3-3	13*	1*
35511045	3-31	1	1	70.3121.1.016	3-39	47	1	70.3535.1.182	3-3	19	1
35511079	3-45	10	1	70.3126.8.002	3-39	3	1	70.3541.1.112	3-43	05**	1
35511080	3-45	2	1	70.3142.3.070	3-33	18	1	70.3542.1.065	3-43	4	1
35511080	3-47	2	1	70.3149.1.001	3-39	24	1	70.3577.7.042	3-19	8	1
35521118	3-39	32	1	70.3162.5.003	3-5	56	1	70.3577.7.047	3-5	76	1
35523018	3-33	8	1	70.3165.1.019	3-39	11	0	70.3577.7.044	3-5	77	1

INDEX

PART NUMBER	PAGE	DET	QTY	PART NUMBER	PAGE	DET	QTY	PART NUMBER	PAGE	DET	QTY
70.3634.3.063	3-33	32	2								
70.3651.3.048	3-7	9	1								
70.3651.8.020	3-27	8	1								
70.3651.8.020	3-31	8	1								
70.3651.8.021	3-29	60	1								
70.3651.8.021	3-31	60	1								
70.3651.8.022	3-27	7	1								
70.3651.8.022	3-31	7	1								
70.3652.3.023	3-9	31	1								
70.3652.3.025	3-11	54	1								
70.3652.3.026	3-11	52	1								
70.3657.2.009	3-19	41	1								
70.3661.1.037	3-45	18	1								
70.3661.1.041	3-47	9	1								
70.3661.1.042	3-45	15	1								
70.3661.1.043	3-47	06*	1								
70.3661.1.045	3-47	6	1								
70.3661.3.100	3-39	8	1								
70.3662.5.002	3-39	25	1								
70.3664.5.006	3-25	49	1								
70.3664.5.007	3-25	46	1								
70.3669.1.008	3-19	21	1								
70.3676.1.032	3-39	7	1								
70.3721.1.153	3-25	11	1								
70.3727.4.013	3-19	23	1								
70.4165.1.097	3-49	14	1								
70.4165.1.112	3-61	7	1								
70.4165.1.114	3-59	2	(1)								
70.4165.1.115	3-59	19*	(1)*								
70.4165.1.116	3-59	20*	(1)*								
70.4165.1.124	3-49	24	1								
70.4165.1.125	3-49	19	1								
70.4165.1.126	3-49	26	1								
70.4165.1.129	3-57	22	1								
70.4223.3.029	3-13	1	1								
70.4253.1.078	3-9	10*	1*								
70.4253.1.078	3-17	01*	1*								
70.4253.1.079	3-9	10**	1**								
70.4253.1.079	3-17	01**	1**								
70.8001.1.001	3-51	14	1								
70.8001.1.002	3-51	12	1								
70.8001.1.004	3-53	1	1								
71.3271.1.021	3-21	97	1								
71.3271.1.022	3-21	96	1								

